

2025



## Signal conditioning and explosion protection

Signal conditioners, measuring transducers, I/O signal marshalling, process displays, and field devices

# Interference-free and safe signal conditioning, transmission, and visualization

Our product portfolio for signal conditioning ensures interference-free signal transmission from the sensor level to the control level. In addition, intrinsically safe, SIL-certified signal conditioners and measuring transducers provide explosion protection and ensure the safety of people, the environment, and the system. You can also control and visualize your process data directly in the field using our process displays.



## 1 Signal conditioners and measuring transducers

- Highly compact MINI Analog Pro signal conditioners and measuring transducers for standard applications and explosion protection
- MACX Analog signal conditioners and measuring transducers for standard applications and explosion protection
- System components and accessories

➤ More information starting on page 6

## 2 I/O signal marshalling

- Signal marshalling for standard I/O systems with Termination Carriers
- Signal marshalling for Universal I/O systems with VIP I/O marshalling

➤ More information starting on page 62



### 3 Process displays and field devices

- Field Analog multifunctional process displays, output loop-powered process displays, and 7-segment LED displays
- Field Analog output loop-powered temperature measuring transducers and head-mounted temperature measuring transducers
- HART® communication
- Resistor network for proximity switches

➤ More information starting on page 84

## Content

Signal conditioning, signal marshalling, and explosion protection	4
Signal conditioners and measuring transducers	6
Highly compact MINI Analog Pro signal conditioners and measuring transducers	8
MACX Analog signal conditioners and measuring transducers	30
System components and accessories	56
I/O signal marshalling	62
Signal marshalling for standard I/O systems	66
Signal marshalling for universal I/O systems	72
Process displays and field devices	82
Process displays	84
Loop-powered temperature measuring transducers	88
HART® communication	94
Resistor network for proximity switches	96
You may also be interested in	98
COMPLETE line	100

# Signal conditioning, signal marshalling, and explosion protection

Standard applications without explosion protection

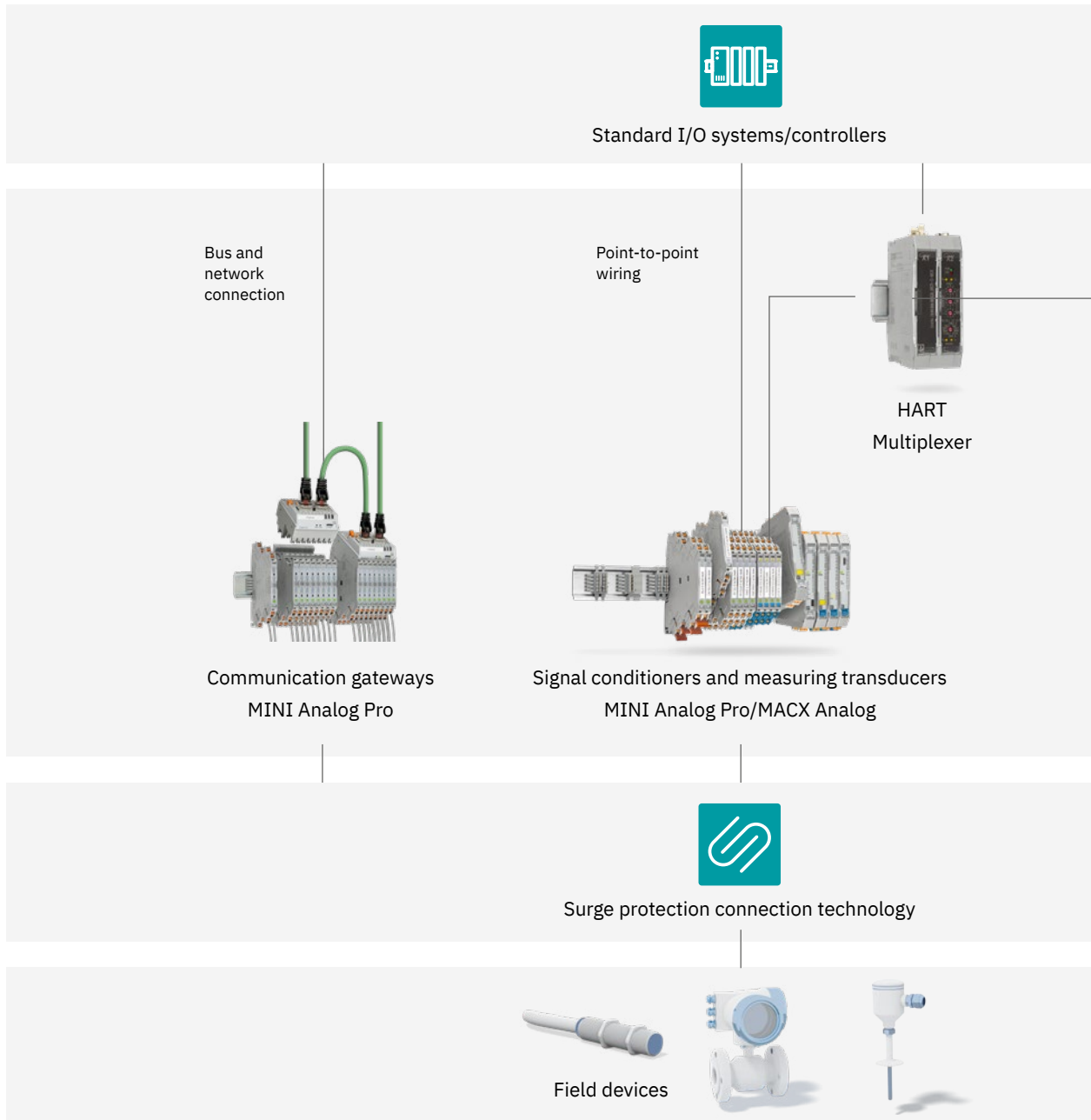

## Signal conditioners and measuring transducers for standard applications

As the interface between the field and the controller, signal conditioners and measuring transducers ensure correct and safe signals.

### Functions of signal conditioners and measuring transducers

In standard signal conditioning applications, signal conditioners and measuring transducers perform the following functions:

- Filtering out unwanted frequencies that negatively influence the signal chain
- Converting signals

- Electrical isolation, preventing signal-distorting ground loops
- Amplifying signals to provide enough power at high loads
- Duplicating signals with electrical isolation, for example, to separate safety circuits and process circuits

### Connection to the I/O or control level

The connection to controllers or I/O systems can be established in various ways:

- Via point-to-point individual wiring
- Via I/O signal marshalling systems for connection via point-to-point system cabling

- Via communication gateways for digitalizing and integrating your process signals into bus and network structures

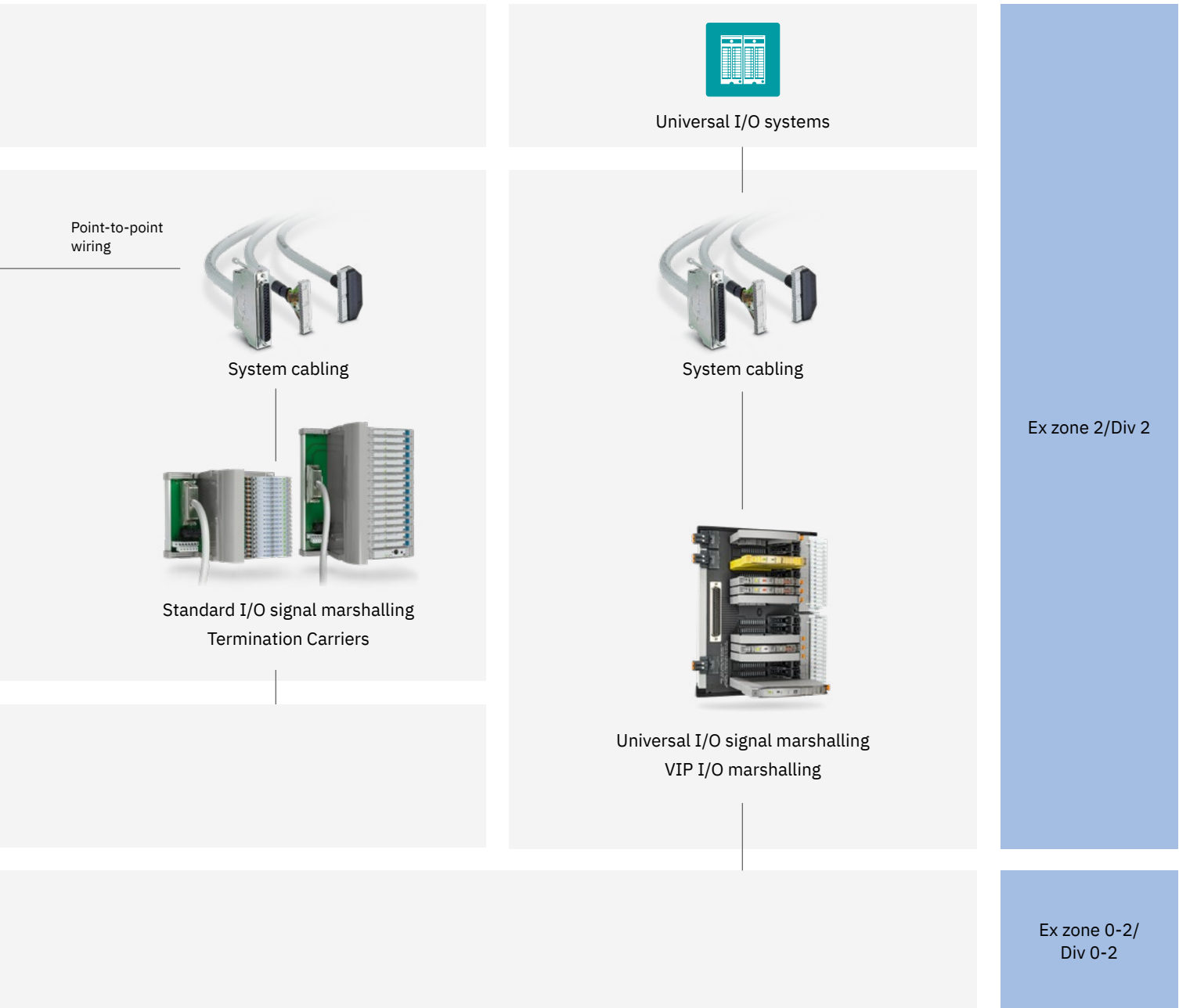

## Signal conditioners and measuring transducers for explosion protection

In addition to their standard functions, signal conditioners and measuring transducers for explosion protection and functional safety ensure the safety of people, systems, and the environment in accordance with the relevant standards:

### Explosion protection:

The consistent Ex i type of protection ensures explosion protection by limiting the electrical energy to the field in areas up to zone 0. The additional type of protection for increased safety, Ex ec, enables the devices to be mounted in areas up to zone 2

and also ensures explosion protection there. In summary, the signal conditioners and measuring transducers from Phoenix Contact provide you with electrical explosion protection for all substance groups and areas.

### Functional safety:

There are systems which, in the event of a fault, pose a risk to the environment and people. It is also important here to avert material system damage. Functional safety is aimed at minimizing these hazards to an acceptable residual risk. Our signal

conditioners and measuring transducers fulfill this task through consistent product development and evaluation in accordance with SIL (IEC 61508) and PL (DIN EN ISO 13849).

### Connection to the I/O or control level

The connection to controllers or I/O systems is established in the same way as in the standard applications.

# Signal conditioners and measuring transducers

1

With our signal conditioners and measuring transducers, you can separate, convert, filter, and amplify signals and cover all tasks of interference-free signal transmission. In intrinsically safe circuits, our Ex i signal conditioners and measuring transducers provide you with explosion protection in up to all zones and substance groups. In addition, products developed consistently for safety applications in accordance with IEC/EN 61508 and PL EN ISO 13849 ensure the safety of people, the environment, and the system.

COMPLETE line

Push-in Technology <sup>3</sup>  
Designed by Phoenix Contact

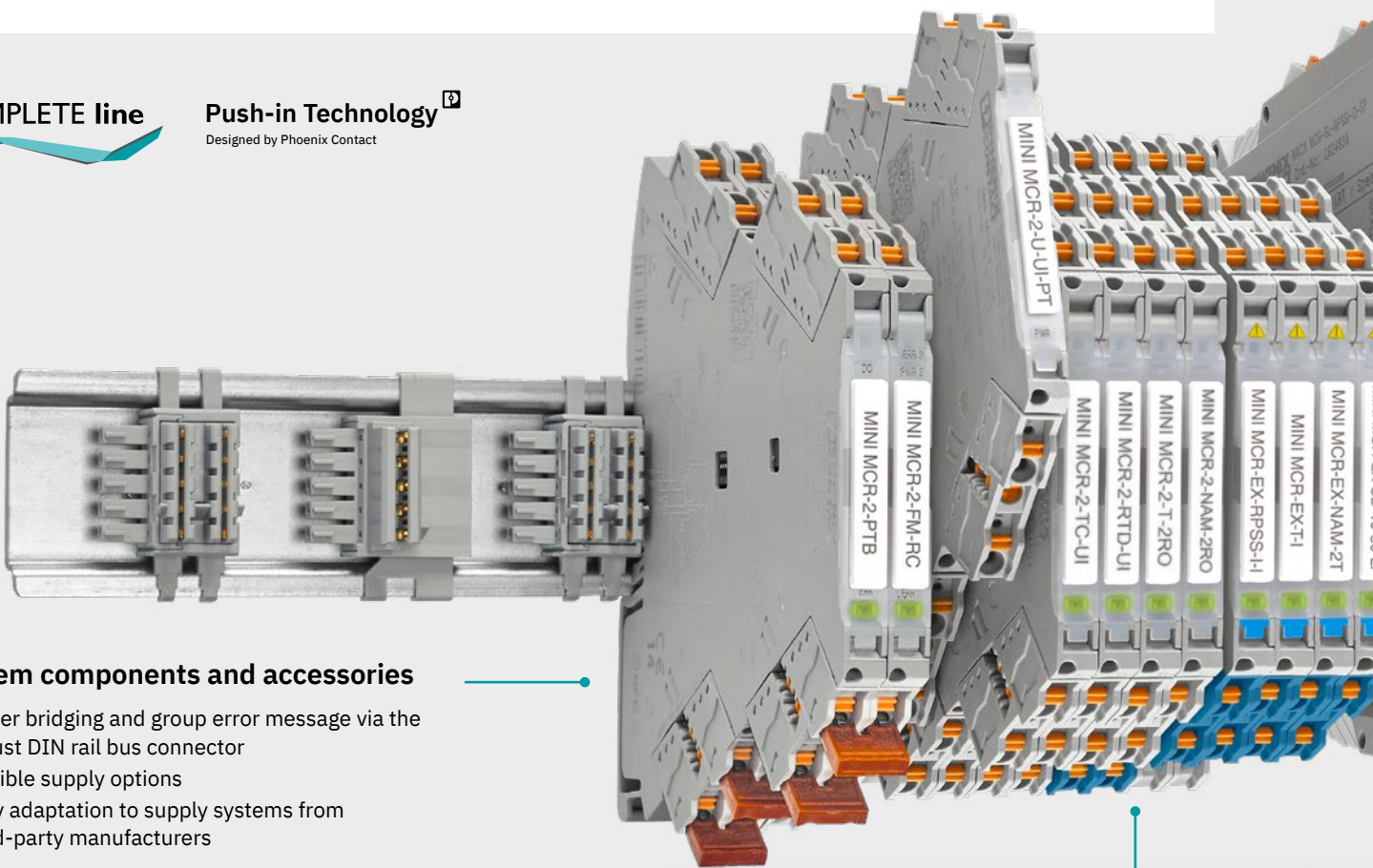

## System components and accessories

- Power bridging and group error message via the robust DIN rail bus connector
- Flexible supply options
- Easy adaptation to supply systems from third-party manufacturers

## Highly compact MINI Analog Pro signal conditioners and measuring transducers for standard applications and explosion protection

- International Ex approvals, consistent extended temperature range
- Ex i versions with consistent suitability for SIL 3 applications
- User-friendly design and operating concept, end-to-end digitalization



## MACX Analog signal conditioners and measuring transducers for standard applications and explosion protection

- International Ex approvals
- Functional safety up to SIL 2 SC 3 or SIL 3, type-specific, versions with performance level
- Two-channel design, versions with wide-range supply

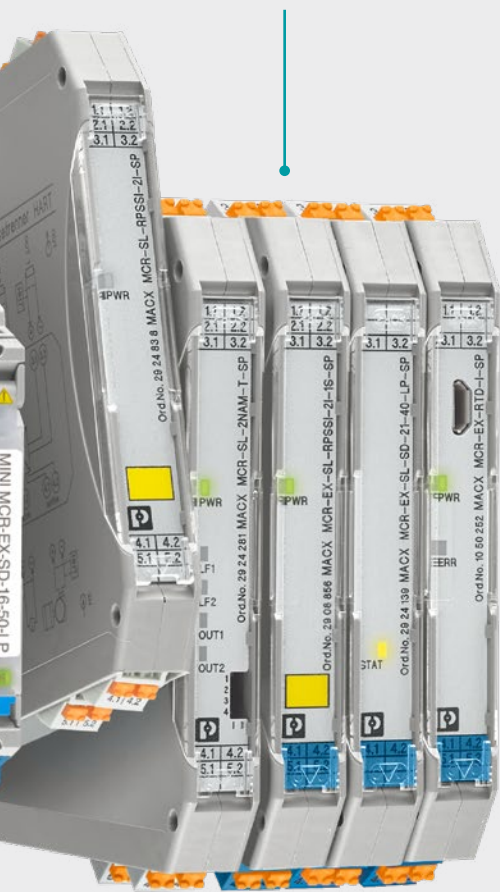

	MINI Analog Pro	MACX Analog
Versions for standard applications	•	•
Versions for Ex i and Ex ec explosion protection	•	•
Consistent SIL 3 1oo1 functional safety: AI, AO, DI, DO	•	-
Functional safety up to SIL 2 SC 3 or SIL 3, type-specific: AI, AO, DI, DO	-	•
PL d, PL c functional safety	-	•
Two-channel design	-	•
Versions with wide-range supply	-	•
Uninterruptible measurement of the current loops	•	-
Plug-in gateways for fieldbus and network connection	•	-
Ambient temperature range of -40°C ... +70°C without derating	•	-
Information retrieval via Signal Conditioner App	NFC and QR code	QR code
Digital nameplate	•	•

## Signal conditioners and measuring transducers with basic functionality

The 6-mm signal conditioners from the MINI Analog range offer the full spectrum of analog signal conditioning for standard applications. The products are reduced to the essentials in terms of space requirements and functionality.

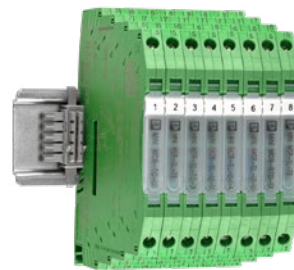

You will find the products on our website:

 **Web code: #1135**



# Your advantages in detail

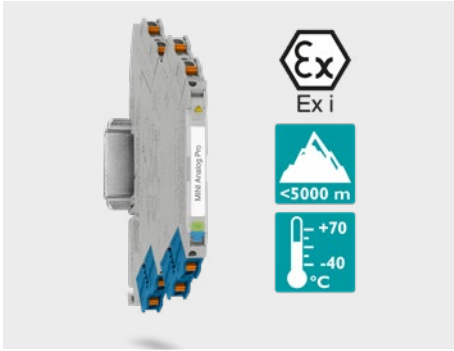

## Explosion protection for all zones and substance groups

MINI Analog Pro Ex i signal conditioners have many international Ex approvals for use in up to all Ex zones and for all substance groups. Furthermore, mining approval, an extended temperature operating range of -40°C to +70°C, and documented requirements for altitude operating ranges of up to 5,000 m enable use in demanding environments.



## A safe solution for every signal type and direction

The MINI Analog Pro Ex i signal conditioners are consistently SIL-certified and provide you with a comprehensive portfolio for all applications up to SIL 3 1oo1. Compared to SIL 2 devices, this has a positive effect on the calculation of your safety-related measuring circuit. At the same time, this also means reduced hardware requirements and prolonged proof test intervals.

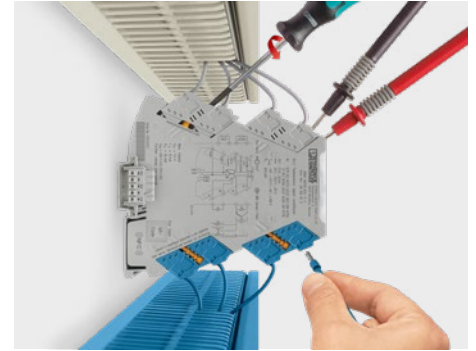

## User-friendly design and operating concept

Space-saving, even between the cable ducts: All connection elements are easily visible and accessible from the front. In addition, plug-in terminal blocks and power bridging with the DIN rail bus connector facilitate installation. Uninterruptible current signal measurement and a wide range of parameterization options simplify commissioning and service.

## Product overview – MINI Analog Pro for standard applications and explosion protection

### Analog IN/OUT

- Universal and standard signal conditioners
- HART®-transparent repeater power supplies and output signal conditioners
- Loop-powered signal conditioners

### Temperature

- Universal measuring transducers for resistance thermometers
- Universal measuring transducers for thermocouples
- Universal temperature measuring transducers for thermocouples and resistance thermometers

### Frequency

- Universal measuring transducers with frequency or PWM input
- Universal analog frequency measuring transducers

### Potentiometers

- Potentiometer measuring transducers with automatic potentiometer detection

### Digital IN

- Isolation switch amplifiers for NAMUR sensors and floating contacts

### Digital OUT

- Solenoid drivers with different output characteristics, loop-powered
- Solenoid drivers with 24 V DC supply voltage, different output characteristics and line fault detection

### Limit values

- Limit value switches with relay changeover contact output

### Accessories

- Plug-in communication gateways
- Partition plate for separating Ex i and non-Ex i signals
- Constant voltage source/ constant current source
- Supply components
- Fault monitoring module
- Marking material

### Analog IN/OUT

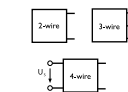

### Temperature

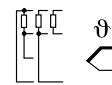

### Frequency

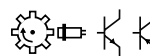

### Potentiometer



### Digital IN

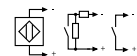

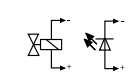

### Digital OUT



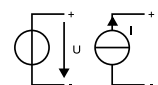

### Limit values

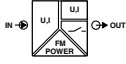

# Product overview – MINI Analog Pro for standard applications

Analog IN/OUT			
			
<b>Product type</b>	Signal conditioner		
			
Description	Universal 4-way signal conditioner with switching output, configurable		
Approvals			
Ex installation	Gc; Div. 2		
Input signal	0 mA ... 24 mA (freely adjustable) 0 V ... 12 V (freely adjustable)		
Output signal	0 mA ... 21 mA (freely adjustable) 0 V ... 10.5 V (freely adjustable)		
Switching output	Switching output (1 N/O contact)		
Supply voltage	9.6 V DC ... 30 V DC		
Ambient temperature range	-40°C ... +70°C		
Fault signaling: LED	Yes		
Fault monitoring	Wire break / short circuit / over-range / under-range / device error		
System adapter (optional)	<a href="#">2901993</a> MINI MCR-2-V8-FLK 16		
Gateway (optional)	<a href="#">2905634</a> MINI MCR-2-V8-MOD-RTU / <a href="#">2905635</a> MINI MCR-2-V8-MOD-TCP / <a href="#">2905636</a> MINI MCR-2-V8-PB-DP / <a href="#">2905637</a> MINI MCR-2-V8-PN		
Termination Carrier (optional)	<a href="#">2906640</a> TC-D37SUB-AIO16-MP-PS-UNI / <a href="#">2906639</a> TC-D37SUB-ADIO16-MP-P-UNI		
Configuration	DIP switch / software / app		
Width	6.2 mm		
Delivery state	Standard configuration		Order configuration
Type	MINI MCR-2-UNI-UI-UIRO(-PT)		MINI MCR-2-UNI-UI-UIRO-PT-C
Connection method	Push-in connection	Screw connection	Push-in connection
Item no.	<a href="#">2902028</a>	<a href="#">2902026</a>	<a href="#">2902027</a>

 The module can be snapped onto the DIN rail bus connector for 24 V voltage bridging

 Wide range input for worldwide supply networks

 Module information:  
• Access module information

# Product overview – MINI Analog Pro for standard applications

1

2

3

Signal conditioners and measuring transducers

Analog IN/OUT						
<b>Product type</b>	Signal conditioner					
Description	3-way signal conditioner, configurable					
Approvals						
Ex installation	Gc; Div. 2					
Input signal	0 mA ... 20 mA / 4 mA ... 20 mA / -20 mA ... 20 mA / 0 V ... 5 V / 1 V ... 5 V / -5 V ... 5 V / 0 V ... 10 V / 2 V ... 10 V / -10 V ... 10 V / 0 V ... 20 V / 4 V ... 20 V / -20 V ... 20 V / 0 V ... 24 V / 4.8 V ... 24 V / -24 V ... 24 V / 0 V ... 30 V / 6 V ... 30 V / -30 V ... 30 V			Unipolar and bipolar (28 ranges each): 0 mV ... 50 mV to 0 V ... 30 V +/-50 mV to +/-30 V		
Output signal	0 mA ... 20 mA / 4 mA ... 20 mA / 0 V ... 5 V / 1 V ... 5 V / -5 V ... 5 V / 0 V ... 10 V / 2 V ... 10 V / -10 V ... 10 V					
Supply voltage	9.6 V DC ... 30 V DC					
Ambient temperature range	-40°C ... +70°C					
Fault signaling: LED	No					
Fault monitoring	Device error					
System adapter (optional)	<a href="#">2901993</a> MINI MCR-2-V8-FLK 16					
Gateway (optional)	<a href="#">2905634</a> MINI MCR-2-V8-MOD-RTU / <a href="#">2905635</a> MINI MCR-2-V8-MOD-TCP / <a href="#">2905636</a> MINI MCR-2-V8-PB-DP / <a href="#">2905637</a> MINI MCR-2-V8-PN					
Termination Carrier (optional)	<a href="#">2906640</a> TC-D37SUB-AIO16-MP-PS-UNI / <a href="#">2906639</a> TC-D37SUB-ADIO16-MP-P-UNI					
Configuration	DIP switch					
Width	6.2 mm					
Delivery state	Standard configuration		Order configuration		Standard configuration	
Type	MINI MCR-2-UI-UI-(PT)		MINI MCR-2-UI-UI-PT-C		MINI MCR-2-U-UI-(PT)	
Connection method	Push-in connection	Screw connection	Push-in connection	Push-in connection	Screw connection	Push-in connection
Item no.	<a href="#">2902040</a>	<a href="#">2902037</a>	<a href="#">2902039</a>	<a href="#">2902021</a>	<a href="#">2902019</a>	<a href="#">2902020</a>



DIP switch settings aid:  
 • Access module information  
 • DIP switch settings aid



Configuration  
 • Access module information  
 • DIP switch settings aid  
 • Module configuration  
 • Bluetooth communication

# Product overview – MINI Analog Pro for standard applications

Analog IN/OUT													
<b>Product type</b>	Signal conditioner												
<b>Description</b>	3-way signal conditioner with fixed signal combinations												
<b>Approvals</b>													
<b>Ex installation</b>	Gc; Div. 2												
<b>Signal transmission behavior</b>	In = out												
<b>Input signal</b>	0 V ... 10 V / -10 V ... 10 V / 2 V ... 10 V			0 mA ... 20 mA / 4 mA ... 20 mA			0 V ... 10 V			0 mA ... 20 mA		4 mA ... 20 mA	
<b>Output signal</b>	0 V ... 10 V / -10 V ... 10 V			0 mA ... 20 mA / 4 mA ... 20 mA			0 mA ... 20 mA		4 mA ... 20 mA		0 V ... 10 V		
<b>Supply voltage</b>	9.6 V DC ... 30 V DC												
<b>Ambient temperature range</b>	-40°C ... +70°C												
<b>Fault signaling: LED</b>	No												
<b>Fault monitoring</b>	Device error												
<b>System adapter (optional)</b>	<a href="#">2901993</a> MINI MCR-2-V8-FLK 16												
<b>Gateway (optional)</b>	<a href="#">2905634</a> MINI MCR-2-V8-MOD-RTU / <a href="#">2905635</a> MINI MCR-2-V8-MOD-TCP / <a href="#">2905636</a> MINI MCR-2-V8-PB-DP / <a href="#">2905637</a> MINI MCR-2-V8-PN												
<b>Termination Carrier (optional)</b>	<a href="#">2906640</a> TC-D37SUB-AIO16-MP-PS-UNI / <a href="#">2906639</a> TC-D37SUB-ADIO16-MP-P-UNI												
<b>Width</b>	6.2 mm												
<b>Delivery state</b>	Standard configuration												
<b>Type</b>	MINI MCR-2-U-U(-PT)		MINI MCR-2-I-I(-PT)		MINI MCR-2-U-I0(-PT)		MINI MCR-2-U-I4(-PT)		MINI MCR-2-I0-U(-PT)		MINI MCR-2-I4-U(-PT)		
<b>Connection method</b>	Push-in connection	Screw connection	Push-in connection	Screw connection	Push-in connection	Screw connection	Push-in connection	Screw connection	Push-in connection	Screw connection	Push-in connection	Screw connection	
<b>Item no.</b>	<a href="#">2902043</a>	<a href="#">2902042</a>	<a href="#">2901999</a>	<a href="#">2901998</a>	<a href="#">2902023</a>	<a href="#">2902022</a>	<a href="#">2902030</a>	<a href="#">2902029</a>	<a href="#">2902001</a>	<a href="#">2902000</a>	<a href="#">2902003</a>	<a href="#">2902002</a>	

The module can be snapped onto the DIN rail bus connector for 24 V voltage bridging









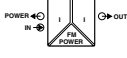

Wide range input for worldwide supply networks

Module information:  
• Access module information

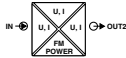
# Product overview – MINI Analog Pro for standard applications

1  
2  
3

Signal conditioners and measuring transducers

Analog IN/OUT							
							
Product type	Repeater power supply				Signal duplicator		
							
Description	3-way repeater power supply, HART-transparent		4-way supply duplicator, HART-transparent		Universal 4-way signal duplicator, configurable		
							
Approvals							
Ex installation	Gc; Div. 2						
Signal transmission behavior	In = out						
Input signal	0 mA ... 20 mA / 4 mA ... 20 mA				0 mA ... 24 mA (freely adjustable) 0 V ... 12 V (freely adjustable)		
Output signal	0 mA ... 20 mA / 4 mA ... 20 mA				0 mA ... 21 mA (freely adjustable) 0 V ... 10.5 V (freely adjustable)		
Supply voltage	9.6 V DC ... 30 V DC						
Ambient temperature range	-40°C ... +70°C						
Fault signaling: LED	No				Yes		
Fault monitoring	Device error				Wire break / short circuit / over-range / under-range / device error		
System adapter (optional)	2901993 MINI MCR-2-V8-FLK 16						
Gateway (optional)	2905634 MINI MCR-2-V8-MOD-RTU / 2905635 MINI MCR-2-V8-MOD-TCP / 2905636 MINI MCR-2-V8-PB-DP / 2905637 MINI MCR-2-V8-PN						
Termination Carrier (optional)	2906640 TC-D37SUB-AIO16-MP-PS-UNI / 2906639 TC-D37SUB-ADIO16-MP-P-UNI						
Configuration				DIP switch		DIP switch / software / app	
Width	6.2 mm						
Delivery state	Standard configuration					Order configuration	
Type	MINI MCR-2-RPSS-I-I(-PT)		MINI MCR-2-RPSS-I-2I(-PT)		MINI MCR-2-UNI-UI-2UI(-PT)		MINI MCR-2-UNI-UI-2UI-PT-C
Connection method	Push-in connection	Screw connection	Push-in connection	Screw connection	Push-in connection	Screw connection	Push-in connection
Item no.	2902015	2902014	2905629	2905628	2905028	2905026	2905027



DIP switch settings aid:  
• Access module information  
• DIP switch settings aid



Configuration  
• Access module information  
• DIP switch settings aid  
• Module configuration  
• Bluetooth communication

# Product overview – MINI Analog Pro for standard applications

Analog IN/OUT							
<b>Product type</b>	Signal conditioner						
<b>Description</b>	Input loop-powered 2-way isolator, 1-channel		Input loop-powered 2-way isolator, 2-channel		Output loop-powered 2-way isolator		
<b>Approvals</b>							
<b>Ex installation</b>	Gc; Div. 2						
<b>Signal transmission behavior</b>	In = out						
<b>Input signal</b>	0 mA ... 20 mA / 4 mA ... 20 mA		Unipolar and bipolar: 0 mA ... 2 mA to 0 mA ... 40 mA (16 ranges) 0 mV ... 50 mV to 0 V ... 30 V (58 ranges)				
<b>Output signal</b>	0 mA ... 20 mA / 4 mA ... 20 mA		4 mA ... 20 mA				
<b>Supply voltage</b>	Loop-powered, no external supply necessary						
<b>Ambient temperature range</b>	-40°C ... +70°C						
<b>Fault signaling: LED</b>	No						
<b>System adapter (optional)</b>	2901993 MINI MCR-2-V8-FLK 16						
<b>Gateway (optional)</b>	2905634 MINI MCR-2-V8-MOD-RTU / 2905635 MINI MCR-2-V8-MOD-TCP / 2905636 MINI MCR-2-V8-PB-DP / 2905637 MINI MCR-2-V8-PN						
<b>Termination Carrier (optional)</b>	2906640 TC-D37SUB-AIO16-MP-PS-UNI / 2906639 TC-D37SUB-ADIO16-MP-P-UNI						
<b>Configuration</b>						DIP switch	
<b>Width</b>	6.2 mm						
<b>Delivery state</b>	Standard configuration						Order configuration
<b>Type</b>	MINI MCR-2-I-I-ILP(-PT)		MINI MCR-2-2I-2I-ILP(-PT)		MINI MCR-2-UI-I-OLP(-PT)		MINI MCR-2-UI-I-OLP-PT-C
<b>Connection method</b>	Push-in connection	Screw connection	Push-in connection	Screw connection	Push-in connection	Screw connection	Push-in connection
<b>Item no.</b>	2901995	2901994	2901997	2901996	2902063	2902061	2902062

The module can be snapped onto the DIN rail bus connector for 24 V voltage bridging

Wide range input for worldwide supply networks

Module information:  
• Access module information

# Product overview – MINI Analog Pro for standard applications

1  
2  
3

Signal conditioners and measuring transducers

Analog IN/OUT						
Product type	Repeater power supply				Output signal conditioner	
Description	Output loop-powered 2-way isolator, 1-channel		Output loop-powered 2-way isolator, 2-channel		Output signal conditioner, HART-transparent	
Approvals						
Ex installation	Gc; Div. 2					
Signal transmission behavior	In = out					
Input signal	0 mA ... 20 mA / 4 mA ... 20 mA					
Output signal	0 mA ... 20 mA / 4 mA ... 20 mA					
Supply voltage	Loop-powered, no external supply necessary				19.2 V DC ... 30 V DC	
Ambient temperature range	-40°C ... +70°C					
Fault signaling: LED	No					
Fault monitoring					Wire break / short circuit / over-range / under-range / device error	
System adapter (optional)	2901993 MINI MCR-2-V8-FLK 16					
Termination Carrier (optional)	2906640 TC-D37SUB-AIO16-MP-PS-UNI / 2906639 TC-D37SUB-ADIO16-MP-P-UNI					
Configuration					DIP switch	
Width	6.2 mm					
Delivery state	Standard configuration					
Type	MINI MCR-2-RPS-I-I-OLP(-PT)		MINI MCR-2-RPS-2I-2I-OLP(-PT)		MINI MCR-2-IDS-I-I(-PT)	
Connection method	Push-in connection	Screw connection	Push-in connection	Screw connection	Push-in connection	Screw connection
Item no.	2906447	2906446	2906449	2906448	2905625	2905623







DIP switch settings aid:  
 • Access module information  
 • DIP switch settings aid



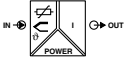

Configuration  
 • Access module information  
 • DIP switch settings aid  
 • Module configuration  
 • Bluetooth communication

# Product overview – MINI Analog Pro for standard applications

Temperature			
			
<b>Product type</b>	Temperature measuring transducer		
			
Description	Universal temperature measuring transducer, configurable		
			
Approvals			
Ex installation	Gc; Div. 2		
Usable input source	RTD: Pt, Ni, Si, Cu sensors / TC: J, K, B, E, N, R, S, T, C, A, L, U, A-1, A-2, A-3, L, M / 2-, 3-, 4-wire		
Input signal	-200°C ... +850°C (range depending on the sensor type) / Linear resistors: 0 Ω ... 40 kΩ (minimum measuring span: 10% of the selected measuring range) / Potentiometer: 0 Ω ... 40 kΩ (minimum measuring span: 10% of selected measuring range) -1000 mV ... 1000 mV		
Output signal	4 mA ... 20 mA / 0 mA ... 20 mA / 20 mA ... 0 mA / 0 mA ... 21 mA / 21 mA ... 0 mA		
Supply voltage	19.2 V DC ... 30 V DC		
Ambient temperature range	-40°C ... +70°C		
Fault signaling: LED	Yes		
Fault monitoring	Wire break / short circuit / over-range / under-range / device error		
System adapter (optional)	<a href="#">2901993</a> MINI MCR-2-V8-FLK 16		
Gateway (optional)	<a href="#">2905634</a> MINI MCR-2-V8-MOD-RTU / <a href="#">2905635</a> MINI MCR-2-V8-MOD-TCP / <a href="#">2905636</a> MINI MCR-2-V8-PB-DP / <a href="#">2905637</a> MINI MCR-2-V8-PN		
Termination Carrier (optional)	<a href="#">2906640</a> TC-D37SUB-AIO16-MP-PS-UNI / <a href="#">2906639</a> TC-D37SUB-ADIO16-MP-P-UNI		
Configuration	Software / app		
Width	6.2 mm		
Delivery state	Standard configuration		Order configuration
Type	MINI MCR-2-T-I(-PT)		MINI MCR-2-T-I-PT-C
Connection method	Push-in connection	Screw connection	Push-in connection
Item no.	<a href="#">2908829</a>	<a href="#">2908828</a>	<a href="#">1472070</a>

 The module can be snapped onto the DIN rail bus connector for 24 V voltage bridging

 Wide range input for worldwide supply networks

 Module information:  
• Access module information

# Product overview – MINI Analog Pro for standard applications

1  
2  
3

Signal conditioners and measuring transducers

Temperature								
<b>Product type</b>	Temperature measuring transducer							
<b>Description</b>	Universal measuring transducer for 2-, 3-, 4-conductor RTDs, configurable			Universal measuring transducer for TC, configurable				
<b>Approvals</b>								
<b>Ex installation</b>	Gc; Div. 2							
<b>Usable input source</b>	RTD: Pt, Ni, Cu sensors / 2, 3, 4-conductor			TC: B, C, E, J, K, N, R, S, T, L, U, A-1, A-2, A-3, M, L				
<b>Input signal</b>	-200°C ... +850°C (range depending on sensor type, range can be set freely via software or in increments from -150°C to +850°C via DIP switches) / Linear resistance: 0 Ω ... 4000 Ω (minimum measuring span: 10% of the selected measuring range)			-250°C ... +2500°C (range depending on sensor type, range can be set freely via software or in increments from -150°C to +1350°C via DIP switches) / -500 mV ... 500 mV (can be set via software)				
<b>Output signal</b>	0 mA ... 21 mA (freely adjustable) 0 V ... 10.5 V (freely adjustable)							
<b>Supply voltage</b>	9.6 V DC ... 30 V DC							
<b>Ambient temperature range</b>	-40°C ... +70°C							
<b>Fault signaling: LED</b>	Yes							
<b>Fault monitoring</b>	Wire break / short circuit / over-range / under-range / device error							
<b>System adapter (optional)</b>	<a href="#">2901993</a> MINI MCR-2-V8-FLK 16							
<b>Gateway (optional)</b>	<a href="#">2905634</a> MINI MCR-2-V8-MOD-RTU / <a href="#">2905635</a> MINI MCR-2-V8-MOD-TCP / <a href="#">2905636</a> MINI MCR-2-V8-PB-DP / <a href="#">2905637</a> MINI MCR-2-V8-PN							
<b>Termination Carrier (optional)</b>	<a href="#">2906640</a> TC-D37SUB-AIO16-MP-PS-UNI / <a href="#">2906639</a> TC-D37SUB-ADIO16-MP-P-UNI							
<b>Configuration</b>	DIP switch / software / app							
<b>Width</b>	6.2 mm							
<b>Delivery state</b>	Standard configuration		Order configuration		Standard configuration			
<b>Type</b>	MINI MCR-2-RTD-UI(-PT)		MINI MCR-2-RTD-UI-PT-C		MINI MCR-2-TC-UI(-PT)			
<b>Connection method</b>	Push-in connection	Screw connection	Push-in connection		Push-in connection	Screw connection		
<b>Item no.</b>	<a href="#">2902052</a>	<a href="#">2902049</a>	<a href="#">2902051</a>		<a href="#">2905249</a>	<a href="#">2902055</a>		



DIP switch settings aid:  
 • Access module information  
 • DIP switch settings aid



Configuration  
 • Access module information  
 • DIP switch settings aid  
 • Module configuration  
 • Bluetooth communication

# Product overview – MINI Analog Pro for standard applications

Frequency						
<b>Product type</b>	Frequency measuring transducer					
<b>Description</b>	Frequency measuring transducer / limit value switch, configurable			Analog frequency measuring transducer / limit value switch, configurable		
<b>Approvals</b>						
<b>Ex installation</b>	Gc; Div. 2					
<b>Usable input source</b>	NAMUR initiator / NPN/PNP transistor outputs / floating contact (dry contact) / frequency generator / incremental encoder (speed only) / HTL rotary transducer / TTL rotary transducer / S0 signal					
<b>Input signal</b>	Frequency: 0.002 Hz ... 200 kHz PWM: 2% ... 98%			0 mA ... 24 mA (freely adjustable) 0 V ... 12 V (freely adjustable)		
<b>Output signal</b>	0 mA ... 21 mA (freely adjustable) 0 V ... 10.5 V (freely adjustable)			Frequency: 0 kHz ... 10 kHz (freely adjustable) PWM: 0% ... 100%		
<b>Switching output</b>	Switching output (1 N/O contact)					
<b>Supply voltage</b>	9.6 V DC ... 30 V DC					
<b>Ambient temperature range</b>	-40°C ... +70°C					
<b>Fault signaling: LED</b>	Yes					
<b>Fault monitoring</b>	Wire break / short circuit / over-range / under-range / device error					
<b>System adapter (optional)</b>	<a href="#">2901993</a> MINI MCR-2-V8-FLK 16					
<b>Gateway (optional)</b>	<a href="#">2905634</a> MINI MCR-2-V8-MOD-RTU / <a href="#">2905635</a> MINI MCR-2-V8-MOD-TCP / <a href="#">2905636</a> MINI MCR-2-V8-PB-DP / <a href="#">2905637</a> MINI MCR-2-V8-PN					
<b>Termination Carrier (optional)</b>	<a href="#">2906640</a> TC-D37SUB-AIO16-MP-PS-UNI / <a href="#">2906639</a> TC-D37SUB-ADIO16-MP-P-UNI					
<b>Configuration</b>	DIP switch / software / app					
<b>Width</b>	6.2 mm					
<b>Delivery state</b>	Standard configuration		Order configuration		Standard configuration	
<b>Type</b>	MINI MCR-2-F-UI(-PT)		MINI MCR-2-F-UI-PT-C		MINI MCR-2-UI-FRO(-PT)	
<b>Connection method</b>	Push-in connection	Screw connection	Push-in connection	Push-in connection	Screw connection	Push-in connection
<b>Item no.</b>	<a href="#">2902058</a>	<a href="#">2902056</a>	<a href="#">2902059</a>	<a href="#">2902032</a>	<a href="#">2902031</a>	<a href="#">2906202</a>

The module can be snapped onto the DIN rail bus connector for 24 V voltage bridging

Wide range input for worldwide supply networks

Module information:  
• Access module information



# Product overview – MINI Analog Pro for standard applications

1

2

3

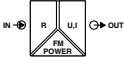
Signal conditioners and measuring transducers

Potentiometers			
			
<b>Product type</b>	Potentiometer measuring transducer		
			
Description	Potentiometer measuring transducer, configurable		
Approvals			
Ex installation	Gc; Div. 2		
Usable input source	3-wire potentiometer		
Input signal	0 Ω ... 100 Ω / 0 Ω ... 100 kΩ		
Output signal	0 mA ... 21 mA (freely adjustable) 0 V ... 10.5 V (freely adjustable)		
Supply voltage	9.6 V DC ... 30 V DC		
Ambient temperature range	-40°C ... +70°C		
Fault signaling: LED	Yes		
Fault monitoring	Wire break / over-range / under-range / device error		
System adapter (optional)	<a href="#">2901993</a> MINI MCR-2-V8-FLK 16		
Gateway (optional)	<a href="#">2905634</a> MINI MCR-2-V8-MOD-RTU / <a href="#">2905635</a> MINI MCR-2-V8-MOD-TCP / <a href="#">2905636</a> MINI MCR-2-V8-PB-DP / <a href="#">2905637</a> MINI MCR-2-V8-PN		
Termination Carrier (optional)	<a href="#">2906640</a> TC-D37SUB-AIO16-MP-PS-UNI / <a href="#">2906639</a> TC-D37SUB-ADIO16-MP-P-UNI		
Configuration	DIP switch / software / app		
Width	6.2 mm		
Delivery state	Standard configuration		Order configuration
Type	MINI MCR-2-POT-UI(-PT)		MINI MCR-2-POT-UI-PT-C
Connection method	Push-in connection	Screw connection	Push-in connection
Item no.	<a href="#">2902017</a>	<a href="#">2902016</a>	<a href="#">2905006</a>



- DIP switch settings aid:
- Access module information
  - DIP switch settings aid



- Configuration
- Access module information
  - DIP switch settings aid
  - Module configuration
  - Bluetooth communication



# Product overview – MINI Analog Pro for standard applications

1  
2  
3

Signal conditioners and measuring transducers

Limit values								
<b>Product type</b>	Limit value switch							
<b>Description</b>	Limit value switch, configurable			Universal limit value switch for 2-, 3-, 4-conductor RTDs and TCs, configurable				
<b>Approvals</b>								
<b>Ex installation</b>	Gc; Div. 2							
<b>Usable input source</b>				RTD: Pt, Ni, Cu sensors / TC: B, E, J, K, N, R, S, T, L, U, A-1, A-2, A-3, M, L				
<b>Input signal</b>	0 mA ... 24 mA (freely adjustable) 0 V ... 12 V (freely adjustable)			-200°C ... + 850°C (depending on sensor) linear resistance: 0 ... 4 kΩ -250°C ... +2500°C (depending on sensor)				
<b>Switching output</b>	Relay output (1 changeover contact)			Relay output (1 N/O contact)		Transistor output (2 N/O contacts)		
<b>Supply voltage</b>	9.6 V DC ... 30 V DC							
<b>Ambient temperature range</b>	-40°C ... +70°C							
<b>Fault signaling: LED</b>	Yes							
<b>Fault monitoring</b>	Over-range / under-range / device error			Wire break / short circuit / over-range / under-range / device error				
<b>System adapter (optional)</b>	<a href="#">2901993</a> MINI MCR-2-V8-FLK 16							
<b>Gateway (optional)</b>	<a href="#">2905634</a> MINI MCR-2-V8-MOD-RTU / <a href="#">2905635</a> MINI MCR-2-V8-MOD-TCP / <a href="#">2905636</a> MINI MCR-2-V8-PB-DP / <a href="#">2905637</a> MINI MCR-2-V8-PN							
<b>Termination Carrier (optional)</b>	<a href="#">2906640</a> TC-D37SUB-AIO16-MP-PS-UNI / <a href="#">2906639</a> TC-D37SUB-ADIO16-MP-P-UNI							
<b>Configuration</b>	DIP switch / software / app							
<b>Width</b>	6.2 mm							
<b>Delivery state</b>	Standard configuration		Order configuration		Standard configuration			
<b>Type</b>	MINI MCR-2-UI-REL(-PT)		MINI MCR-2-UI-REL-PT-C		MINI MCR-2-T-REL(-PT)		MINI MCR-2-T-2RO(-PT)	
<b>Connection method</b>	Push-in connection	Screw connection	Push-in connection		Push-in connection	Screw connection	Push-in connection	Screw connection
<b>Item no.</b>	<a href="#">2902035</a>	<a href="#">2902033</a>	<a href="#">2909887</a>		<a href="#">2905633</a>	<a href="#">2905632</a>	<a href="#">2906877</a>	<a href="#">2906876</a>



DIP switch settings aid:  
 • Access module information  
 • DIP switch settings aid



Configuration  
 • Access module information  
 • DIP switch settings aid  
 • Module configuration  
 • Bluetooth communication

# Product overview – MINI Analog Pro for standard applications

Accessories			
<b>Product type</b>	Constant voltage source		
<b>Description</b>	Constant voltage source/constant current source		Constant voltage source, sensor power supply
<b>Approvals</b>			
<b>Ex installation</b>	Gc; Div. 2		
<b>Output signal</b>	10 V DC / 8.75 V DC / 7.5 V DC / 6.25 V DC / 5 V DC / 3.75 V DC / 2.5 V DC / 1.25 V DC / 20 mA / 17.5 mA / 15 mA / 12.5 mA / 10 mA / 7.5 mA / 5 mA / 2.5 mA		15 V DC
<b>Supply voltage</b>	9.6 V DC ... 30 V DC		
<b>Ambient temperature range</b>	-40°C ... +70°C		
<b>Fault signaling: LED</b>	No		
<b>Fault monitoring</b>	Device error		
<b>Configuration</b>	DIP switch		
<b>Width</b>	6.2 mm		
<b>Delivery state</b>	Standard configuration		
<b>Type</b>	MINI MCR-2-CVCS(-PT)		MINI MCR-2S-24-15(-PT)
<b>Connection method</b>	Push-in connection	Screw connection	Push-in connection Screw connection
<b>Item no.</b>	<a href="#">2902065</a>	<a href="#">2902064</a>	<a href="#">1033201</a> <a href="#">1033202</a>

The module can be snapped onto the DIN rail bus connector for 24 V voltage bridging







Wide range input for worldwide supply networks

Module information:  
• Access module information

# Product overview – MINI Analog Pro for explosion protection

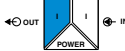
1  
2  
3

Signal conditioners and measuring transducers

Analog IN/OUT				
				
<b>Product type</b>	Repeater power supply		Output signal conditioner	
				
<b>Description</b>	Ex i repeater power supply, HART-transparent		Ex i output signal conditioner, HART-transparent	
				
<b>Approvals</b>				
<b>Ex installation / Ex i switching circuit</b>	Gc; Div. 2 / Ga; Da; Ma; Div. 1			
<b>Functional safety</b>	SIL 3			
<b>Signal transmission behavior</b>	In = out			
<b>Input signal</b>	0 mA ... 20 mA / 4 mA ... 20 mA			
<b>Output signal</b>	0 mA ... 20 mA / 4 mA ... 20 mA			
<b>Supply voltage</b>	19.2 V DC ... 30 V DC			
<b>Ambient temperature range</b>	-40°C ... +70°C			
<b>Fault signaling: LED</b>	No			
<b>Fault monitoring</b>	Wire break / short circuit / over-range / under-range / device error			
<b>System adapter (optional)</b>	2901993 MINI MCR-2-V8-FLK 16			
<b>Gateway (optional)</b>	2905634 MINI MCR-2-V8-MOD-RTU / 2905635 MINI MCR-2-V8-MOD-TCP / 2905636 MINI MCR-2-V8-PB-DP / 2905637 MINI MCR-2-V8-PN			
<b>Configuration</b>			DIP switch	
<b>Width</b>	6.2 mm			
<b>Delivery state</b>	Standard configuration			
<b>Type</b>	MINI MCR-EX-RPSS-I-I(-PT)		MINI MCR-EX-IDS-I-I(-PT)	
<b>Connection method</b>	Push-in connection	Screw connection	Push-in connection	Screw connection
<b>Item no.</b>	2908804	2908803	2908806	2908805





DIP switch settings aid:  
 • Access module information  
 • DIP switch settings aid



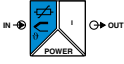

Configuration  
 • Access module information  
 • DIP switch settings aid  
 • Module configuration  
 • Bluetooth communication

# Product overview – MINI Analog Pro for explosion protection

Temperature			
			
<b>Product type</b>	Temperature measuring transducer		
			
Description	Universal Ex i temperature measuring transducer, configurable		
			
Approvals	DNV  		
Ex installation / Ex i switching circuit	Gc; Div. 2 / Ga; Da; Ma; Div. 1		
Functional safety	SIL 2 / SC 3		
Usable input source	RTD: Pt, Ni, Si, Cu sensors / TC: J, K, B, E, N, R, S, T, C, A, L, U, A-1, A-2, A-3, L, M / 2-, 3-, 4-wire		
Input signal	-200°C ... +850°C (range depending on the sensor type) / Linear resistors: 0 Ω ... 40 kΩ (minimum measuring span: 10% of the selected measuring range) / Potentiometer: 0 Ω ... 40 kΩ (minimum measuring span: 10% of selected measuring range) -1000 mV ... 1000 mV		
Output signal	4 mA ... 20 mA / 4 mA ... 20 mA / 0 mA ... 20 mA / 20 mA ... 0 mA / 0 mA ... 21 mA / 21 mA ... 0 mA		
Supply voltage	19.2 V DC ... 30 V DC		
Ambient temperature range	-40°C ... +70°C		
Fault signaling: LED	Yes		
Fault monitoring	Wire break / short circuit / over-range / under-range / device error		
System adapter (optional)	<a href="#">2901993</a> MINI MCR-2-V8-FLK 16		
Gateway (optional)	<a href="#">2905634</a> MINI MCR-2-V8-MOD-RTU / <a href="#">2905635</a> MINI MCR-2-V8-MOD-TCP / <a href="#">2905636</a> MINI MCR-2-V8-PB-DP / <a href="#">2905637</a> MINI MCR-2-V8-PN		
Configuration	Software / app		
Width	6.2 mm		
Delivery state	Standard configuration		Order configuration
Type	MINI MCR-EX-T-I(-PT)		MINI MCR-EX-T-I-PT-C
Connection method	Push-in connection	Screw connection	Push-in connection
Item no.	<a href="#">2908814</a>	<a href="#">2908813</a>	<a href="#">1472132</a>

 The module can be snapped onto the DIN rail bus connector for 24 V voltage bridging

 Wide range input for worldwide supply networks

 Module information:  
• Access module information

# Product overview – MINI Analog Pro for explosion protection

1  
2  
3

Signal conditioners and measuring transducers

Digital IN						
<b>Product type</b>	Isolation switch amplifier					
<b>Description</b>	Ex i NAMUR isolation switch amplifier, configurable					
<b>Approvals</b>						
<b>Approvals</b>						
<b>Ex installation / Ex i switching circuit</b>	Gc; Div. 2 / Ga; Da; Ma; Div. 1					
<b>Functional safety</b>	SIL 3					
<b>Usable input source</b>	NAMUR proximity sensors (IEC/EN 60947-5-6) / floating switch contacts / switching contacts with resistance circuits					
<b>Switching output</b>	Transistor output (passive)			Relay output (solid-state relay)		
<b>Supply voltage</b>	19.2 V DC ... 30 V DC					
<b>Ambient temperature range</b>	-40°C ... +70°C					
<b>Fault signaling: LED</b>	Yes					
<b>Fault monitoring</b>	Wire break / short circuit / device error					
<b>System adapter (optional)</b>	2901993 MINI MCR-2-V8-FLK 16					
<b>Gateway (optional)</b>				2905634 MINI MCR-2-V8-MOD-RTU / 2905635 MINI MCR-2-V8-MOD-TCP / 2905636 MINI MCR-2-V8-PB-DP / 2905637 MINI MCR-2-V8-PN		
<b>Configuration</b>	DIP switch					
<b>Width</b>	6.2 mm					
<b>Delivery state</b>	Standard configuration					
<b>Type</b>	MINI MCR-EX-NAM-T(-PT)		MINI MCR-EX-NAM-2T(-PT)		MINI MCR-EX-NAM-RO(-PT)	
<b>Connection method</b>	Push-in connection	Screw connection	Push-in connection	Screw connection	Push-in connection	Screw connection
<b>Item no.</b>	2908808	2908807	1157854	1157852	1157857	1157862





- DIP switch settings aid:
- Access module information
  - DIP switch settings aid



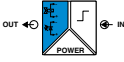

- Configuration
- Access module information
  - DIP switch settings aid
  - Module configuration
  - Bluetooth communication

# Product overview – MINI Analog Pro for explosion protection

Digital OUT								
								
<b>Product type</b>		Solenoid driver						
								
<b>Description</b>	Ex i solenoid driver, with logic input and line fault detection, current limitation at 50 mA		Ex i solenoid driver, with logic input and line fault detection, current limitation at 25 mA		Ex i solenoid driver, with logic input and line fault detection, current limitation at 48 mA		Ex i solenoid driver, with logic input and line fault detection, current limitation at 38 mA	
<b>Approvals</b>								
<b>Ex installation / Ex i switching circuit</b>	Gc; Div. 2 / Ga; Da; Ma; Div. 1							
<b>Functional safety</b>	SIL 3							
<b>Input signal</b>	Switching level "0" signal: 0 V DC ... 5 V DC Switching level "1" signal: 15 V DC ... 30 V DC							
<b>Output signal</b>	Output voltage: ≥10.7 V DC (50 mA) / no-load voltage: >16 V DC / current limitation: >50 mA (with line fault detection) / output resistance: ≥103 Ω (internal resistance Ri)	Output voltage: ≥9.6 V DC (25 mA) / no-load voltage: >20 V DC / current limitation: >25 mA (with line fault detection) / output resistance: ≥413 Ω (internal resistance Ri)	Output voltage: ≥12.2 V DC (48 mA) / no-load voltage: >21 V DC / current limitation: >48 mA (with line fault detection) / output resistance: ≥181 Ω (internal resistance Ri)	Output voltage: ≥12.5 V DC (38 mA) / no-load voltage: >23 V DC / current limitation: >38 mA (with line fault detection) / output resistance: ≥270 Ω (internal resistance Ri)				
<b>Supply voltage</b>	19.2 V DC ... 30 V DC							
<b>Ambient temperature range</b>	-40°C ... +70°C							
<b>Fault signaling: LED</b>	Yes							
<b>Fault monitoring</b>	Wire break / short circuit / device error							
<b>System adapter (optional)</b>	2901993 MINI MCR-2-V8-FLK 16							
<b>Width</b>	6.2 mm							
<b>Delivery state</b>	Standard configuration							
<b>Type</b>	MINI MCR-EX-SD-16-50-LFD(-PT)		MINI MCR-EX-SD-20-25-LFD(-PT)		MINI MCR-EX-SD-21-48-LFD(-PT)		MINI MCR-EX-SD-23-38-LFD(-PT)	
<b>Connection method</b>	Push-in connection	Screw connection	Push-in connection	Screw connection	Push-in connection	Screw connection	Push-in connection	Screw connection
<b>Item no.</b>	1175904	1175902	1175897	1175891	1175884	1175877	1277119	1277116

 The module can be snapped onto the DIN rail bus connector for 24 V voltage bridging

 Wide range input for worldwide supply networks

 Module information:  
• Access module information

# Product overview – MINI Analog Pro for explosion protection

1

2

3

Signal conditioners and measuring transducers

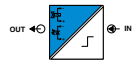
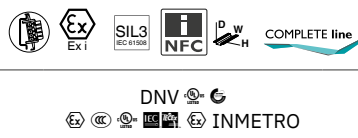
Digital OUT								
								
<b>Product type</b>	Solenoid driver							
								
Description	Ex i solenoid driver, loop-powered, current limitation at 50 mA		Ex i solenoid driver, loop-powered, current limitation at 25 mA		Ex i solenoid driver, loop-powered, current limitation at 48 mA		Ex i solenoid driver, loop-powered, current limitation at 38 mA	
Approvals								
Ex installation / Ex i switching circuit	Gc; Div. 2 / Ga; Da; Ma; Div. 1							
Functional safety	SIL 3							
Input signal	19.2 V DC ... 30 V DC							
Output signal	Output voltage: ≥10.7 V DC (50 mA) / no-load voltage: >16 V DC / current limitation: >50 mA / output resistance: ≥103 Ω (internal resistance Ri)	Output voltage: ≥9.6 V DC (25 mA) / no-load voltage: >20 V DC / current limitation: >25 mA / output resistance: ≥413 Ω (internal resistance Ri)	Output voltage: ≥12.2 V DC (48 mA) / no-load voltage: >21 V DC / current limitation: >48 mA / output resistance: ≥181 Ω (internal resistance Ri)	Output voltage: ≥12.5 V DC (38 mA) / no-load voltage: >23 V DC / current limitation: >38 mA / output resistance: ≥270 Ω (internal resistance Ri)				
Supply voltage	Loop-powered, no external supply necessary							
Ambient temperature range	-40°C ... +70°C							
Fault signaling: LED	No							
System adapter (optional)	<a href="#">2901993</a> MINI MCR-2-V8-FLK 16							
Width	6.2 mm							
Delivery state	Standard configuration							
Type	MINI MCR-EX-SD-16-50-LP(-PT)		MINI MCR-EX-SD-20-25-LP(-PT)		MINI MCR-EX-SD-21-48-LP(-PT)		MINI MCR-EX-SD-23-38-LP(-PT)	
Connection method	Push-in connection	Screw connection	Push-in connection	Screw connection	Push-in connection	Screw connection	Push-in connection	Screw connection
Item no.	<a href="#">1157870</a>	<a href="#">1157869</a>	<a href="#">1157868</a>	<a href="#">1157867</a>	<a href="#">2908811</a>	<a href="#">2908810</a>	<a href="#">1277114</a>	<a href="#">1277111</a>



- DIP switch settings aid:
- Access module information
  - DIP switch settings aid



- Configuration
- Access module information
  - DIP switch settings aid
  - Module configuration
  - Bluetooth communication

# MINI Analog Pro bus and network connection

## Digitalizing analog signals: plug-in MINI Analog Pro communication gateways

The plug-in MINI Analog Pro gateways combine the advantages of safe electrical isolation with the benefits of digital communication. With an overall width of less than 50 mm, they can transmit, free of interference, up to eight field signals to industrial bus systems and networks. You can eliminate the need for signal-specific input cards. At the same time, you can benefit from consistent electrical isolation right through to the controller, including between the individual channels.

### Your advantages

- Space-saving network integration of signal conditioners in any combination
- Safe electrical isolation, including between the individual channels
- Signal-specific I/O input cards are no longer required
- Measure current signals during operation or take readings via NFC in the app
- Quick parameterization via rotary coding switch, software, or app



## Easy integration into PROFINET networks

Using the MINI Analog Pro PROFINET gateway, various analog and digital signals can be integrated into PROFINET networks. The switch from PROFIBUS to PROFINET protocol is particularly interesting for refitting projects.

The gateway has been certified by the PROFIBUS Nutzerorganisation e.V. user organization in accordance with Conformance Class C and can therefore be easily migrated into a wide range of applications.

The plug-and-play principle also helps in this application. Disconnect the output terminal on the MINI Analog Pro signal conditioners, plug in the PROFINET gateway, connect the network cables – and you're done.

Additional gateways are available for the following protocols: Modbus/TCP, Modbus/RTU, and PROFIBUS.

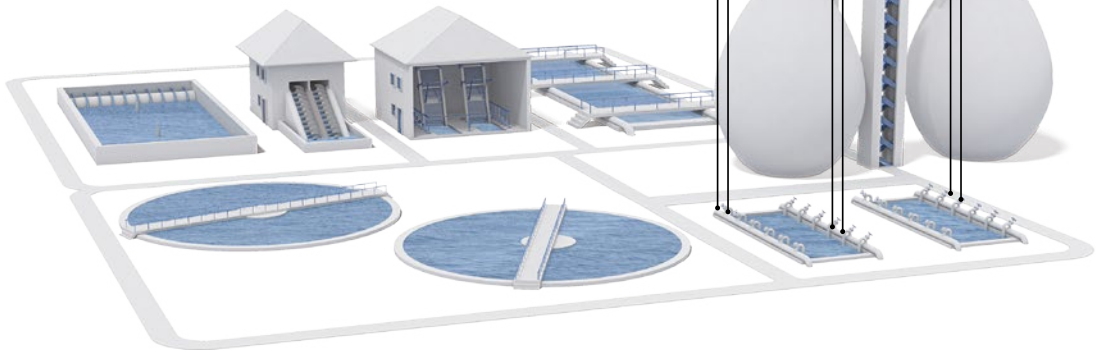
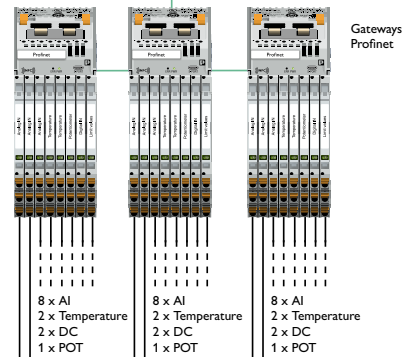





## Product overview – MINI Analog Pro bus and network connection

1

2

3

Signal conditioners and measuring transducers

Gateways			
	Description	Item no.	Type
	Eight MINI Analog Pro signal conditioners and measuring transducers are quickly and easily integrated into a Modbus/RTU network via a communication adapter.	2905634	MINI MCR-2-V8-MOD-RTU
	Eight MINI Analog Pro signal conditioners and measuring transducers are quickly and easily integrated into a Modbus/TCP network via a communication adapter.	2905635	MINI MCR-2-V8-MOD-TCP
	Eight MINI Analog Pro signal conditioners and measuring transducers are quickly and easily integrated into a PROFIBUS DP network via a communication adapter.	2905636	MINI MCR-2-V8-PB-DP
	Eight MINI Analog Pro signal conditioners and measuring transducers are quickly and easily integrated into a PROFINET network via a communication adapter.	2905637	MINI MCR-2-V8-PN

# MACX Analog signal conditioners and measuring transducers

The MACX Analog signal conditioners and measuring transducers offer you a comprehensive range of solutions for safe and reliable signal conditioning. In intrinsically safe circuits, the Ex i versions provide you with explosion protection in up to all zones and substance groups. The products, developed consistently for safety applications for IEC/EN 61508 and PL EN ISO 13849, ensure the safety of people, the environment, and the system.

COMPLETE line

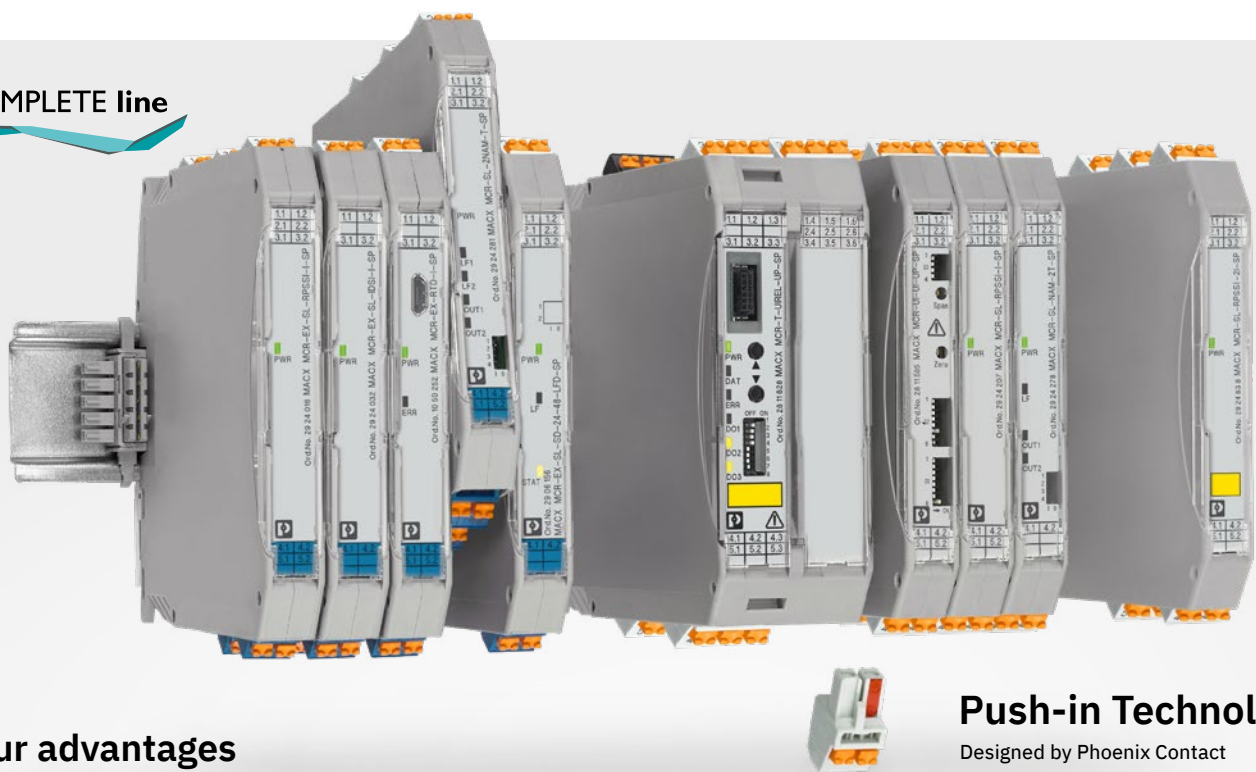

## Your advantages

- ✓ Broad international Ex approval package, including mining and marine approvals
- ✓ Reliable and safe in all safety-related applications up to SIL 2 SC 3 or SIL 3
- ✓ Versions with Performance Level certification in accordance with EN ISO 13849
- ✓ Overall width of just 12.5 mm for single- and two-channel products with standard functions
- ✓ Flexible supply: modular 24 V power bridging with group error messaging or wide range input up to 230 V AC/DC

**Push-in Technology**   
Designed by Phoenix Contact

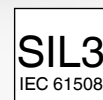

# Your advantages in detail



## Comprehensive explosion protection for all zones and substance groups

MACX Analog Ex i signal conditioners and measuring transducers have a wide package of international Ex approvals for use in up to all Ex zones and for all substance groups. In addition, mining and marine approvals, as well as versions with an extended temperature operating range of -40 to +70°C and documented requirements for altitude operating ranges up to 5,000 m, enable use in demanding environments.



## Functional safety for the process industry and machine building

Our MACX Analog Ex signal conditioners and measuring transducers are available for all safety-related applications up to SIL 2 SC 3 or SIL 3. Selected products have PL certification for use in machine building. This applies to both standard applications and explosion protection.

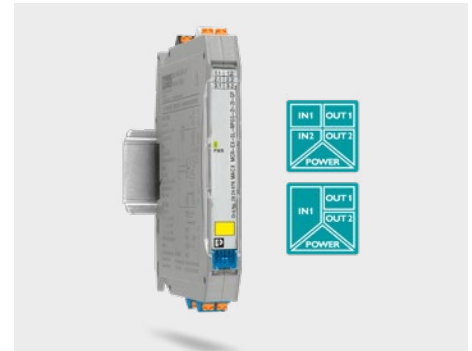

## Two-channel design and signal duplication with an overall width of just 12.5 mm

Save space with two-channel versions and signal duplicators with an overall width of just 12.5 mm.

### Product overview – MACX Analog for standard applications and explosion protection

#### Analog IN/OUT

- Universal and standard signal conditioners
- HART-transparent repeater power supplies and output signal conditioners
- Loop-powered signal conditioners

#### Temperature

- Universal measuring transducers for resistance thermometers, thermocouples, resistance-type sensors, potentiometers, and mV sources, with limit value switching
- Standard temperature measuring transducers for resistance thermometers or thermocouples

#### Frequency

- Two-channel measuring transducers with NAMUR signal input (IEC/EN 60947-5-6)

#### Digital IN

- Isolation switch amplifiers for NAMUR sensors and floating contacts, with relay, transistor, or NAMUR

output (resistive in accordance with EN 6079-5-6)

#### Digital OUT

- Solenoid drivers with different output characteristics, loop-powered
- Solenoid drivers with 24 V DC supply voltage, different output characteristics and line fault detection

#### Limit values

- Limit value switches with relay changeover contact output

#### Accessories

- Partition plate for separating Ex i and non-Ex i signals
- Constant voltage source/constant current source
- Supply components
- Feed-in module with fault monitoring for the power bridging system with the DIN rail bus connector
- Marking material

#### Analog IN/OUT

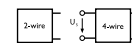

#### Temperature

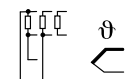

#### Frequency

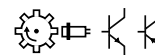

#### Potentiometer

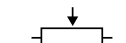

#### Digital IN

#### Digital IN

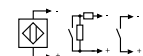



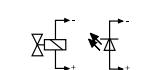



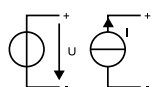





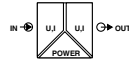



















#### Digital OUT



#### Limit values



# Product overview – MACX Analog for standard applications

Analog IN/OUT						
						
<b>Product type</b>	Signal conditioner					
						
<b>Description</b>	3-way signal conditioner, configurable, wide-range supply			3-way signal conditioner, configurable		
						
<b>Approvals</b>	DNV                           					

# Product overview – MACX Analog for standard applications

1  
2  
3





Signal conditioners and measuring transducers

Analog IN								
<b>Product type</b>	Repeater power supply							
<b>Description</b>	Repeater power supply and input signal conditioner, HART-transparent, wide-range supply		Repeater power supply and input signal conditioner, HART-transparent		Repeater power supply and input signal conditioner with two outputs, HART-transparent		Repeater power supply, 2-channel, HART-transparent	
<b>Approvals</b>								
<b>Ex installation</b>	Gc; Div. 2							
<b>Functional safety</b>	SIL 2 / SC 3				SIL 2 / SC 3 / PL d / KAT 2		SIL 3 / PL d	
<b>Signal transmission behavior</b>	In = out							
<b>Input signal</b>	0 mA ... 20 mA / 4 mA ... 20 mA						4 mA ... 20 mA	
<b>Output signal</b>	0 mA ... 20 mA / 4 mA ... 20 mA / 0 V ... 5 V / 1 V ... 5 V		0 mA ... 20 mA / 4 mA ... 20 mA				4 mA ... 20 mA	
<b>Supply voltage</b>	19.2 V AC/DC ... 253 V AC/DC		19.2 V DC ... 30 V DC					
<b>Ambient temperature range</b>	-40°C ... +60°C (+70°C: derating)							
<b>Fault signaling: LED</b>	No							
<b>Termination Carrier (optional)</b>			2924854 TC-D37SUB-ADIO16-EX-P-UNI / 2902932 TC-D37SUB-AIO16-EX-PS-UNI		2904684 TC-2D37SUB-ADIO32-2EX-P-UNI			
<b>Configuration</b>	DIP switch							
<b>Width</b>	17.5 mm		12.5 mm					
<b>Delivery state</b>	Standard configuration							
<b>Type</b>	MACX MCR-SL-RPSSI-I-UP(-SP)		MACX MCR-SL-RPSSI-I(-SP)		MACX MCR-SL-RPSSI-2I(-SP)		MACX MCR-SL-RPSS-2I-2I(-SP)	
<b>Connection method</b>	Push-in connection	Screw connection	Push-in connection	Screw connection	Push-in connection	Screw connection	Push-in connection	Screw connection
<b>Item no.</b>	2924210	2865968	2924207	2865955	2924838	2924825	2904090	2904089

The module can be snapped onto the DIN rail bus connector for 24 V voltage bridging

Wide range input for worldwide supply networks

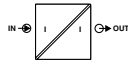
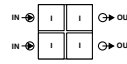



# Product overview – MACX Analog for standard applications

Analog IN				
				
<b>Product type</b>	Signal conditioner			
				
<b>Description</b>	Input-loop-powered 2-way isolator, 1-channel		Input-loop-powered 2-way isolator, 2-channel	
				
<b>Approvals</b>				
<b>Ex installation</b>	Gc; Div. 2			
<b>Functional safety</b>	SIL 3			
<b>Signal transmission behavior</b>	In = out			
<b>Input signal</b>	0 mA ... 20 mA / 4 mA ... 20 mA			
<b>Output signal</b>	0 mA ... 20 mA / 4 mA ... 20 mA			
<b>Supply voltage</b>	Loop-powered, no external supply necessary			
<b>Ambient temperature range</b>	-40°C ... +85°C			
<b>Fault signaling: LED</b>	No			
<b>Width</b>	12.5 mm			
<b>Delivery state</b>	Standard configuration			
<b>Type</b>	MACX MCR-SL-I-I-ILP(-SP)		MACX MCR-SL-2I-2I-ILP(-SP)	
<b>Connection method</b>	Push-in connection	Screw connection	Push-in connection	Screw connection
<b>Item no.</b>	2905279	2905278	2905281	2905280

# Product overview – MACX Analog for standard applications

1  
2  
3

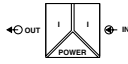
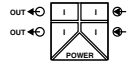











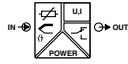
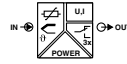



Signal conditioners and measuring transducers

Analog OUT			
			
<b>Product type</b>	Output signal conditioner		
			
<b>Description</b>	Output signal conditioner, HART-transparent		Output signal conditioner, 2-channel, HART-transparent
<b>Approvals</b>			
<b>Ex installation</b>	Gc; Div. 2		
<b>Functional safety</b>	SIL 2 / SC 3		SIL 3 / SC 3
<b>Signal transmission behavior</b>	In = out		
<b>Input signal</b>	0 mA ... 20 mA / 0.2 mA ... 20 mA / 4 mA ... 20 mA		0.2 mA ... 20 mA / 4 mA ... 20 mA
<b>Output signal</b>	0 mA ... 20 mA / 0.2 mA ... 20 mA / 4 mA ... 20 mA		0.2 mA ... 20 mA / 4 mA ... 20 mA
<b>Supply voltage</b>	19.2 V DC ... 30 V DC		
<b>Ambient temperature range</b>	-40°C ... +70°C		
<b>Fault signaling: LED</b>	No		
<b>Termination Carrier (optional)</b>	<a href="#">2902932</a> TC-D37SUB-AIO16-EX-PS-UNI / <a href="#">2924854</a> TC-D37SUB-ADIO16-EX-P-UNI		<a href="#">2904684</a> TC-2D37SUB-ADIO32-2EX-P-UNI
<b>Configuration</b>	DIP switch		
<b>Width</b>	12.5 mm		
<b>Delivery state</b>	Standard configuration		
<b>Type</b>	MACX MCR-IDS-I-I(-SP)		MACX MCR-IDS-2I-2I(-SP)
<b>Connection method</b>	Push-in connection	Screw connection	Push-in connection Screw connection
<b>Item no.</b>	<a href="#">2908064</a>	<a href="#">2908063</a>	<a href="#">2908066</a> <a href="#">2908065</a>

 The module can be snapped onto the DIN rail bus connector for 24 V voltage bridging

 Wide range input for worldwide supply networks

# Product overview – MACX Analog for standard applications

Temperature						
						
<b>Product type</b>	Temperature measuring transducer					
						
<b>Description</b>	Universal temperature measuring transducer, with limit value relay, wide-range supply, configurable			Universal Ex i temperature measuring transducer, with 3 limit value relays, wide-range supply, configurable		
	    					
<b>Approvals</b>	DNV          INMETRO					
<b>Ex installation</b>	Gc; Div. 2					
<b>Functional safety</b>	SIL 2 / SC 2 / PL d					
<b>Usable input source</b>	RTD: Pt, Ni, Cu sensors / 2, 3, 4-conductor / TC: B, E, J, K, N, R, S, T, L, U, CA, DA, A1G, A2G, A3G, MG, LG					
<b>Input signal</b>	-250°C ... +2500°C (range depending on the sensor type) / linear resistance: 0 Ω ... 50 kΩ / potentiometer: 0 Ω ... 50 kΩ / -1000 mV ... 1000 mV					
<b>Output signal</b>	0 mA ... 20 mA / 4 mA ... 20 mA					
<b>Switching output</b>	Relay output (1 changeover contact)			Relay output (3 changeover contacts)		
<b>Supply voltage</b>	19.2 V AC/DC ... 253 V AC/DC					
<b>Ambient temperature range</b>	-20°C ... +65°C					
<b>Fault signaling: LED</b>	Yes					
<b>Fault monitoring</b>	Wire break / short circuit / over-range / under-range / device error					
<b>Configuration</b>	DIP switch / software					
<b>Width</b>	17.5 mm			35 mm		
<b>Delivery state</b>	Standard configuration		Order configuration		Order configuration	
<b>Type</b>	MACX MCR-T-UI-UP(-SP)		MACX MCR-T-UI-UP-SP-C		MACX MCR-T-UIREL-UP(-SP)	
<b>Connection method</b>	Push-in connection	Screw connection	Push-in connection		Push-in connection	Screw connection
<b>Item no.</b>	<a href="#">2811860</a>	<a href="#">2811394</a>	<a href="#">2811970</a>	<a href="#">2811828</a>	<a href="#">2811378</a>	<a href="#">2811831</a>







# Product overview – MACX Analog for standard applications

1

2

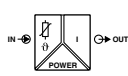
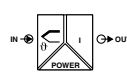
3

Signal conditioners and measuring transducers

Temperature				
				
<b>Product type</b>	Temperature measuring transducer			
				
<b>Description</b>	Temperature measuring transducer for RTD sensors, configurable		Temperature measuring transducer for TC sensors, configurable	
				
<b>Approvals</b>				
<b>Ex installation</b>	Gc; Div. 2			
<b>Functional safety</b>	SIL 2 / SC 2			
<b>Usable input source</b>	RTD: Pt, Ni, Cu sensors: 2, 3, 4-conductor		TC: B, E, J, K, N, R, S, T, L, U, C, D, A-1, A-2, A-3, M, Lr	
<b>Input signal</b>	-200°C ... +850°C (range depending on the sensor type) / linear resistance: 0 Ω ... 50 kΩ / potentiometer: 0 Ω ... 50 kΩ		-250°C ... +2500°C (range depending on the sensor type) / -1000 mV ... 1000 mV	
<b>Output signal</b>	0 mA ... 20 mA / 4 mA ... 20 mA			
<b>Supply voltage</b>	19.2 V DC ... 30 V DC			
<b>Ambient temperature range</b>	-40°C ... +70°C			
<b>Fault signaling: LED</b>	Yes			
<b>Fault monitoring</b>	Wire break / short circuit / over-range / under-range / device error		Wire break / over-range / under-range / device error	
<b>Configuration</b>	Software			
<b>Width</b>	12.5 mm			
<b>Delivery state</b>	Standard configuration	Order configuration	Standard configuration	Order configuration
<b>Type</b>	MACX MCR-RTD-I(-SP)	MACX MCR-RTD-I-SP-C	MACX MCR-TC-I	MACX MCR-TC-I-C
<b>Connection method</b>	Push-in connection	Push-in connection	Screw connection	
<b>Item no.</b>	1050201	1050192	1052464	1052459





The module can be snapped onto the DIN rail bus connector for 24 V voltage bridging

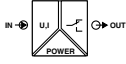

Wide range input for worldwide supply networks

# Product overview – MACX Analog for standard applications

Limit values			
			
<b>Product type</b>	Limit value switch		
			
Description	Limit value switch, configurable		
			
Approvals			
Ex installation	Gc; Div. 2		
Functional safety	SIL 2 / SC 3 / PL c		
Input signal	0.2 mA ... 20 mA 0.1 V ... 10 V		
Switching output	Relay output (1 changeover contact)		
Supply voltage	9.6 V DC ... 30 V DC		
Ambient temperature range	-20°C ... +65°C		
Fault signaling: LED	Yes		
Fault monitoring	Wire break / short circuit / device error		
Configuration	DIP switch		
Width	12.5 mm		
Delivery state	Standard configuration		
Type	MACX MCR-SL-UI-REL(-SP)		
Connection method	<table border="1" style="width: 100%; border-collapse: collapse;"> <tr> <td style="width: 50%; text-align: center;">Push-in connection</td> <td style="width: 50%; text-align: center;">Screw connection</td> </tr> </table>	Push-in connection	Screw connection
Push-in connection	Screw connection		
Item no.	<table border="1" style="width: 100%; border-collapse: collapse;"> <tr> <td style="width: 50%; text-align: center;">2906170</td> <td style="width: 50%; text-align: center;">2906169</td> </tr> </table>	2906170	2906169
2906170	2906169		

# Product overview – MACX Analog for standard applications

1  
2  
3













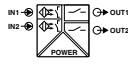
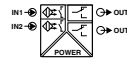

Signal conditioners and measuring transducers

Digital IN			
<b>Product type</b>	Isolation switch amplifier		
Description	NAMUR isolation switch amplifier		
Approvals	 DNV 		
Ex installation	Gc; Div. 2		
Functional safety	SIL 2 / SC 3		
Usable input source	NAMUR proximity sensors (IEC/EN 60947-5-6) / floating switch contacts / switching contacts with resistance circuits		
Switching output	Relay output (1 changeover contact)	Relay output (2 N/O contacts)	
Supply voltage	19.2 V DC ... 30 V DC		
Ambient temperature range	-40°C ... +60°C (+70°C: derating)		
Fault signaling: LED	Yes		
Fault monitoring	Wire break / short circuit / device error		
Termination Carrier (optional)	<a href="#">2924854</a> TC-D37SUB-ADIO16-EX-P-UNI	<a href="#">2904684</a> TC-2D37SUB-ADIO32-2EX-P-UNI	
Configuration	DIP switch		
Width	12.5 mm		
Delivery state	Standard configuration		
Type	MACX MCR-SL-NAM-R(-SP)		MACX MCR-SL-NAM-2RO(-SP)
Connection method	Push-in connection	Screw connection	Push-in connection / Screw connection
Item no.	<a href="#">2924252</a>	<a href="#">2865997</a>	<a href="#">2924265</a> / <a href="#">2865010</a>

The module can be snapped onto the DIN rail bus connector for 24 V voltage bridging

Wide range input for worldwide supply networks





# Product overview – MACX Analog for standard applications

Digital IN				
				
<b>Product type</b>	Isolation switch amplifier			
				
<b>Description</b>	NAMUR isolation switch amplifier, 2-channel			
				
<b>Approvals</b>	DNV     		DNV     	
<b>Ex installation</b>	Gc; Div. 2			
<b>Functional safety</b>	SIL 2 / SC 3			
<b>Usable input source</b>	NAMUR proximity sensors (IEC/EN 60947-5-6) / floating switch contacts / switching contacts with resistance circuits			
<b>Switching output</b>	Relay output (1 N/O contact per channel)		Relay output (1 changeover contact per channel)	
<b>Supply voltage</b>	19.2 V DC ... 30 V DC		19.2 V AC/DC ... 253 V AC/DC	
<b>Ambient temperature range</b>	-40°C ... +60°C (+70°C: derating)			
<b>Fault signaling: LED</b>	Yes			
<b>Fault monitoring</b>	Wire break / short circuit / device error			
<b>Termination Carrier (optional)</b>	<a href="#">2904684</a> TC-2D37SUB-ADIO32-2EX-P-UNI			
<b>Configuration</b>	DIP switch			
<b>Width</b>	12.5 mm		17.5 mm	
<b>Delivery state</b>	Standard configuration			
<b>Type</b>	MACX MCR-SL-2NAM-RO(-SP)		MACX MCR-SL-2NAM-R-UP(-SP)	
<b>Connection method</b>	Push-in connection	Screw connection	Push-in connection	Screw connection
<b>Item no.</b>	<a href="#">2924294</a>	<a href="#">2865049</a>	<a href="#">2924304</a>	<a href="#">2865052</a>

# Product overview – MACX Analog for standard applications

1  
2  
3

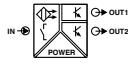
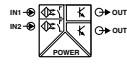





Signal conditioners and measuring transducers

Digital IN			
			
<b>Product type</b>	Isolation switch amplifier		
			
<b>Description</b>	NAMUR isolation switch amplifier		NAMUR isolation switch amplifier, 2-channel
<b>Approvals</b>			
<b>Ex installation</b>	Gc; Div. 2		
<b>Functional safety</b>	SIL 2 / SC 3		
<b>Usable input source</b>	NAMUR proximity sensors (IEC/EN 60947-5-6) / floating switch contacts / switching contacts with resistance circuits		
<b>Output signal</b>	2 transistor outputs, passive Switching voltage: ≤30 V DC Switching current: ≤50 mA Switching frequency: ≤5 kHz Signal output 2 can also be configured as an error message output		1 transistor output per channel, passive Switching voltage: ≤30 V DC Switching current: ≤50 mA Switching frequency: ≤5 kHz
<b>Switching output</b>	Transistor output (passive)		
<b>Supply voltage</b>	19.2 V DC ... 30 V DC		
<b>Ambient temperature range</b>	-40°C ... +60°C (+70°C: derating)		
<b>Fault signaling: LED</b>	Yes		
<b>Fault monitoring</b>	Wire break / short circuit / device error		
<b>Termination Carrier (optional)</b>	<a href="#">2904684</a> TC-2D37SUB-ADIO32-2EX-P-UNI		
<b>Configuration</b>	DIP switch		
<b>Width</b>	12.5 mm		
<b>Delivery state</b>	Standard configuration		
<b>Type</b>	MACX MCR-SL-NAM-2T(-SP)		MACX MCR-SL-2NAM-T(-SP)
<b>Connection method</b>	Push-in connection	Screw connection	Push-in connection Screw connection
<b>Item no.</b>	<a href="#">2924278</a>	<a href="#">2865023</a>	<a href="#">2924281</a> <a href="#">2865036</a>

 The module can be snapped onto the DIN rail bus connector for 24 V voltage bridging

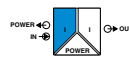
 Wide range input for worldwide supply networks





# Product overview – MACX Analog for explosion protection

Analog IN			
			
<b>Product type</b>	Repeater power supply		
			
<b>Description</b>	Ex i repeater power supply and input signal conditioner, HART-transparent, wide-range supply		Ex i repeater power supply and input signal conditioner, HART-transparent
			
<b>Approvals</b>			
<b>Ex installation / Ex i switching circuit</b>	Gc; Div. 2 / Ga; Da; Ma; Div. 1		
<b>Functional safety</b>	SIL 2 / SC 3		
<b>Signal transmission behavior</b>	In = out		
<b>Input signal</b>	0 mA ... 20 mA / 4 mA ... 20 mA		
<b>Output signal</b>	0 mA ... 20 mA / 4 mA ... 20 mA 0 V ... 5 V / 1 V ... 5 V		0 mA ... 20 mA / 4 mA ... 20 mA
<b>Supply voltage</b>	19.2 V AC/DC ... 253 V AC/DC		19.2 V DC ... 30 V DC
<b>Ambient temperature range</b>	-40°C ... +60°C (+70°C: derating)		
<b>Fault signaling: LED</b>	No		
<b>Termination Carrier (optional)</b>	<a href="#">2924854</a> TC-D37SUB-ADIO16-EX-P-UNI / <a href="#">2902932</a> TC-D37SUB-AIO16-EX-PS-UNI		
<b>Configuration</b>	DIP switch		
<b>Width</b>	17.5 mm		12.5 mm
<b>Delivery state</b>	Standard configuration		
<b>Type</b>	MACX MCR-EX-SL-RPSSI-I-UP(-SP)		MACX MCR-EX-SL-RPSSI-I(-SP)
<b>Connection method</b>	Push-in connection	Screw connection	Push-in connection Screw connection
<b>Item no.</b>	<a href="#">2924029</a>	<a href="#">2865793</a>	<a href="#">2924016</a> <a href="#">2865340</a>

# Product overview – MACX Analog for explosion protection

1  
2  
3

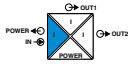
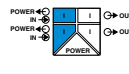



Signal conditioners and measuring transducers

Analog IN						
						
<b>Product type</b>	Repeater power supply					
						
<b>Description</b>	Ex i repeater power supply and input signal conditioner with two outputs, HART-transparent		Ex i repeater power supply and input signal conditioner with two outputs, only one channel HART-transparent		Ex i repeater power supply, 2-channel, HART-transparent	
<b>Approvals</b>						
<b>Ex installation / Ex i switching circuit</b>	Gc; Div. 2 / Ga; Da; Ma; Div. 1					
<b>Functional safety</b>	SIL 2 / SC 3 / PL d / KAT 2			SIL 3 / PL d		
<b>Signal transmission behavior</b>	In = out					
<b>Input signal</b>	0 mA ... 20 mA / 4 mA ... 20 mA			4 mA ... 20 mA		
<b>Output signal</b>	0 mA ... 20 mA / 4 mA ... 20 mA			4 mA ... 20 mA		
<b>Supply voltage</b>	19.2 V DC ... 30 V DC					
<b>Ambient temperature range</b>	-40°C ... +60°C (+70°C: derating)					
<b>Fault signaling: LED</b>	No					
<b>Termination Carrier (optional)</b>	2904684 TC-2D37SUB-ADIO32-2EX-P-UNI					
<b>Width</b>	12.5 mm					
<b>Delivery state</b>	Standard configuration					
<b>Type</b>	MACX MCR-EX-SL-RPSSI-2I(-SP)		MACX MCR-EX-SL-RPSSI-2I-1S(-SP)		MACX MCR-EX-SL-RPSS-2I-2I(-SP)	
<b>Connection method</b>	Push-in connection	Screw connection	Push-in connection	Screw connection	Push-in connection	Screw connection
<b>Item no.</b>	2924236	2865366	2908856	2908855	2924676	2865382

 The module can be snapped onto the DIN rail bus connector for 24 V voltage bridging

 Wide range input for worldwide supply networks

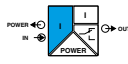
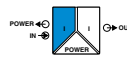
# Product overview – MACX Analog for explosion protection

Analog IN				
				
<b>Product type</b>	Repeater power supply			
				
<b>Description</b>	Ex i repeater power supply and input signal conditioner, HART-transparent, limit value outputs		Ex i repeater power supply and input signal conditioner, HART-transparent, also for 3-conductor sensors	
<b>Approvals</b>				
<b>Ex installation / Ex i switching circuit</b>	Gc / Ga; Da; Ma			
<b>Functional safety</b>	SIL 2		SIL 3	
<b>Signal transmission behavior</b>	In = out			
<b>Input signal</b>	4 mA ... 20 mA		0 mA ... 20 mA / 4 mA ... 20 mA	
<b>Output signal</b>	4 mA ... 20 mA		0 mA ... 20 mA / 4 mA ... 20 mA	
<b>Switching output</b>	Relay output (2 N/O contacts)			
<b>Supply voltage</b>	18 V ... 31.2 V			
<b>Ambient temperature range</b>	-40°C ... +70°C		-20°C ... +70°C	
<b>Fault signaling: LED</b>	Yes			
<b>Width</b>	17.5 mm			
<b>Delivery state</b>	Standard configuration			
<b>Type</b>	MACX MCR-EX-AP-RPSS-I-IR(-SP)		MACX MCR-EX-AP-RPSS-I-I(-SP)	
<b>Connection method</b>	Push-in connection	Screw connection	Push-in connection	Screw connection
<b>Item no.</b>	1290776	1290774	1291193	1291191







# Product overview – MACX Analog for explosion protection

1

2

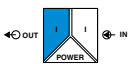
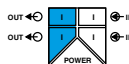
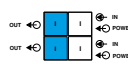
3

Signal conditioners and measuring transducers

Analog OUT						
						
<b>Product type</b>	Output signal conditioner					
						
<b>Description</b>	Ex i output signal conditioner, HART-transparent		Ex i output signal conditioner, 2-channel, HART-transparent		Ex i output signal conditioner, 2-channel, HART-transparent, input loop-powered	
<b>Approvals</b>						
<b>Ex installation / Ex i switching circuit</b>	Gc; Div. 2 / Ga; Da; Ma; Div. 1				Gc / Ga; Da; Ma	
<b>Functional safety</b>	SIL 2 / SC 3		SIL 3 / SC 3		SIL 3	
<b>Signal transmission behavior</b>	In = out					
<b>Input signal</b>	0 mA ... 20 mA / 0.2 mA ... 20 mA / 4 mA ... 20 mA		0.2 mA ... 20 mA / 4 mA ... 20 mA		0 mA ... 20 mA / 4 mA ... 20 mA	
<b>Output signal</b>	0 mA ... 20 mA / 0.2 mA ... 20 mA / 4 mA ... 20 mA		0.2 mA ... 20 mA / 4 mA ... 20 mA		0 mA ... 20 mA / 4 mA ... 20 mA	
<b>Supply voltage</b>	19.2 V DC ... 30 V DC				Loop-powered, no external supply necessary	
<b>Ambient temperature range</b>	-40°C ... +70°C				-20°C ... +70°C	
<b>Fault signaling: LED</b>	No					
<b>Termination Carrier (optional)</b>	2924854 TC-D37SUB-ADIO16-EX-P-UNI / 2902932 TC-D37SUB-AIO16-EX-PS-UNI		2904684 TC-2D37SUB-ADIO32-2EX-P-UNI			
<b>Configuration</b>	DIP switch					
<b>Width</b>	12.5 mm				17.5 mm	
<b>Delivery state</b>	Standard configuration					
<b>Type</b>	MACX MCR-EX-IDS-I-I(-SP)		MACX MCR-EX-IDS-2I-2I(-SP)		MACX MCR-EX-AP-IDS-2I-2I-LP(-SP)	
<b>Connection method</b>	Push-in connection	Screw connection	Push-in connection	Screw connection	Push-in connection	Screw connection
<b>Item no.</b>	2908062	2908060	2904931	2865421	1291983	1291963













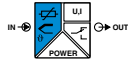
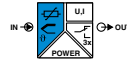







The module can be snapped onto the DIN rail bus connector for 24 V voltage bridging



Wide range input for worldwide supply networks





# Product overview – MACX Analog for explosion protection

Temperature					
					
<b>Product type</b>	Temperature measuring transducer				
					
<b>Description</b>	Universal Ex i temperature measuring transducer, with limit value relay, wide-range supply, configurable		Universal Ex i temperature measuring transducer, with 3 limit value relays, wide-range supply, configurable		
	    				
<b>Approvals</b>	DNV      KC-s		DNV     		
<b>Ex installation / Ex i switching circuit</b>	Gc; Div. 2 / Ga; Da; Ma; Div. 1				
<b>Functional safety</b>	SIL 2 / SC 2 / PL d				
<b>Usable input source</b>	RTD: Pt, Ni, Cu sensors / 2, 3, 4-conductor / TC: B, E, J, K, N, R, S, T, L, U, CA, DA, A1G, A2G, A3G, MG, LG				
<b>Input signal</b>	-250°C ... +2500°C (range depending on the sensor type) / linear resistance: 0 Ω ... 50 kΩ / potentiometer: 0 Ω ... 50 kΩ / -1000 mV ... 1000 mV				
<b>Output signal</b>	0 mA ... 20 mA / 4 mA ... 20 mA				
<b>Switching output</b>	Relay output (1 changeover contact)		Relay output (3 changeover contacts)		
<b>Supply voltage</b>	19.2 V AC/DC ... 253 V AC/DC				
<b>Ambient temperature range</b>	-20°C ... +65°C				
<b>Fault signaling: LED</b>	Yes				
<b>Fault monitoring</b>	Wire break / short circuit / over-range / under-range / device error				
<b>Configuration</b>	DIP switch / software				
<b>Width</b>	17.5 mm		35 mm		
<b>Delivery state</b>	Standard configuration	Order configuration	Standard configuration	Order configuration	
<b>Type</b>	MACX MCR-EX-T-UI-UP(-SP)	MACX MCR-EX-T-UI-UP-SP-C	MACX MCR-EX-T-UIREL-UP(-SP)	MACX MCR-EX-T-UIREL-UP-SP-C	
<b>Connection method</b>	Push-in connection	Screw connection	Push-in connection	Push-in connection	Screw connection
<b>Item no.</b>	2924689	2865654	2924692	2924799	2865751
					2924809

# Product overview – MACX Analog for explosion protection

1  
2  
3

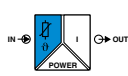
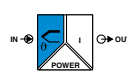



Signal conditioners and measuring transducers

Temperature					
					
<b>Product type</b>	Temperature measuring transducer				
					
<b>Description</b>	Ex i temperature measuring transducer for RTD sensors, configurable		Ex i temperature measuring transducer for TC sensors, configurable		
<b>Approvals</b>					
<b>Ex installation / Ex i switching circuit</b>	Gc; Div. 2 / Ga; Da; Ma; Div. 1				
<b>Functional safety</b>	SIL 2 / SC 2				
<b>Usable input source</b>	RTD: Pt, Ni, Cu sensors: 2, 3, 4-conductor		TC: B, E, J, K, N, R, S, T, L, U, C, D, A-1, A-2, A-3, M, Lr		
<b>Input signal</b>	-200°C ... +850°C (range depending on the sensor type) / linear resistance: 0 Ω ... 50 kΩ / potentiometer: 0 Ω ... 50 kΩ		-250°C ... +2500°C (range depending on the sensor type) / -1000 mV ... 1000 mV		
<b>Output signal</b>	0 mA ... 20 mA / 4 mA ... 20 mA				
<b>Supply voltage</b>	19.2 V DC ... 30 V DC				
<b>Ambient temperature range</b>	-40°C ... +70°C				
<b>Fault signaling: LED</b>	Yes				
<b>Fault monitoring</b>	Wire break / short circuit / over-range / under-range / device error		Wire break / over-range / under-range / device error		
<b>Configuration</b>	Software				
<b>Width</b>	12.5 mm				
<b>Delivery state</b>	Standard configuration	Order configuration	Standard configuration	Order configuration	
<b>Type</b>	MACX MCR-EX-RTD-I(-SP)	MACX MCR-EX-RTD-I-SP-C	MACX MCR-EX-TC-I	MACX MCR-EX-TC-I-C	
<b>Connection method</b>	Push-in connection	Screw connection	Push-in connection	Screw connection	
<b>Item no.</b>	<a href="#">1050252</a>	<a href="#">1050222</a>	<a href="#">1052652</a>	<a href="#">1050233</a>	<a href="#">1052458</a>

 The module can be snapped onto the DIN rail bus connector for 24 V voltage bridging

 Wide range input for worldwide supply networks

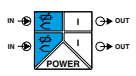
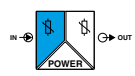
# Product overview – MACX Analog for explosion protection

Temperature			
			
<b>Product type</b>	Temperature measuring transducer		
			
<b>Description</b>	Universal Ex i temperature measuring transducer, 2-channel		Ex i resistance isolator
			
<b>Approvals</b>			
<b>Ex installation / Ex i switching circuit</b>	Gc / Ga; Da; Ma		
<b>Signal transmission behavior</b>		In = out	
<b>Usable input source</b>	RTD: Pt 100, Pt 250, Pt 500, Pt 1000, Pt 2000, Ni 100, Ni 500, Ni 1000, M50, M53, M100 / TC: B, E, J, K, N, R, S, T, L, U, XK / 2-, 3-, 4-conductor		RTD: Pt 100 / 2-, 3-, 4-conductor
<b>Input signal</b>	-200°C ... +1100°C (range depending on the sensor type)		Linear resistance: 18 Ω ... 391 Ω (Pt 100)
<b>Output signal</b>	0 mA ... 20 mA / 4 mA ... 20 mA		Linear resistance: 18 Ω ... 391 Ω (Pt 100)
<b>Supply voltage</b>	18 V ... 31.2 V		
<b>Ambient temperature range</b>	-20°C ... +70°C		
<b>Fault signaling: LED</b>	Yes		
<b>Configuration</b>	Software		
<b>Width</b>	17.5 mm		
<b>Delivery state</b>	Standard configuration		
<b>Type</b>	MACX MCR-EX-AP-2T-2I(-SP)		MACX MCR-EX-AP-RTD-RTD(-SP)
<b>Connection method</b>	Push-in connection	Screw connection	Push-in connection Screw connection
<b>Item no.</b>	1290849	1290780	1291955 1291894



# Product overview – MACX Analog for explosion protection

1

2

3

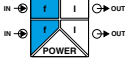
Signal conditioners and measuring transducers

Frequency			
			
Product type	Frequency measuring transducer		
			
Description	Ex i frequency measuring transducer, 2-channel		
			
Approvals			
Ex installation / Ex i switching circuit	Gc / Ga; Da; Ma		
Usable input source	In accordance with IEC/EN 60947-5-6 NAMUR		
Input signal	0.001 Hz ... 20000 Hz		
Output signal	0 mA ... 20 mA / 4 mA ... 20 mA		
Supply voltage	18 V ... 31.2 V		
Ambient temperature range	-40°C ... +70°C		
Fault signaling: LED	Yes		
Configuration	Software		
Width	17.5 mm		
Delivery state	Standard configuration		
Type	MACX MCR-EX-AP-2F-2I(-SP)		
Connection method	<table border="1" style="width: 100%;"> <tr> <td style="width: 50%; text-align: center;">Push-in connection</td> <td style="width: 50%; text-align: center;">Screw connection</td> </tr> </table>	Push-in connection	Screw connection
Push-in connection	Screw connection		
Item no.	<table border="1" style="width: 100%;"> <tr> <td style="width: 50%; text-align: center;">1290533</td> <td style="width: 50%; text-align: center;">1290530</td> </tr> </table>	1290533	1290530
1290533	1290530		











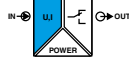

The module can be snapped onto the DIN rail bus connector for 24 V voltage bridging



Wide range input for worldwide supply networks

# Product overview – MACX Analog for explosion protection

Limit values	
	
<b>Product type</b>	Limit value switch
	
Description	Ex i limit value switch, configurable
	
Approvals	DNV          INMETRO
Ex installation / Ex i switching circuit	Gc; Div. 2 / Ga; Da; Ma; Div. 1
Functional safety	SIL 2 / SC 3 / PL c
Input signal	0.2 mA ... 20 mA 0.1 V ... 10 V
Switching output	Relay output (1 changeover contact)
Supply voltage	9.6 V DC ... 30 V DC
Ambient temperature range	-20°C ... +65°C
Fault signaling: LED	Yes
Fault monitoring	Wire break / short circuit / device error
Configuration	DIP switch / potentiometer
Width	12.5 mm
Delivery state	Standard configuration
Type	MACX MCR-EX-SL-UI-REL(-SP)
Connection method	<div style="display: flex; justify-content: space-around;"> <span>Push-in connection</span> <span>Screw connection</span> </div>
Item no.	<div style="display: flex; justify-content: space-around;"> <span>2906165</span> <span>2906164</span> </div>

# Product overview – MACX Analog for explosion protection

1  
2  
3







Signal conditioners and measuring transducers

Digital IN								
Product type	Isolation switch amplifier							
Description	Ex i NAMUR isolation switch amplifier				Ex i NAMUR isolation switch amplifier, 2-channel			
Approvals	DNV 				DNV 			
Ex installation / Ex i switching circuit	Gc; Div. 2 / Ga; Da; Ma; Div. 1							
Functional safety	SIL 2 / SC 3							
Usable input source	NAMUR proximity sensors (IEC/EN 60947-5-6) / floating circuit contacts / switch contacts with resistance circuit							
Switching output	Relay output (1 changeover contact)		Relay output (2 N/O contacts)		Relay output (1 N/O contact per channel)		Relay output (1 changeover contact per channel)	
Supply voltage	19.2 V DC ... 30 V DC						19.2 V AC/DC ... 253 V AC/DC	
Ambient temperature range	-40°C ... +60°C (+70°C: derating)							
Fault signaling: LED	Yes							
Fault monitoring	Wire break / short circuit / device error							
Termination Carrier (optional)	2924854 TC-D37SUB-ADIO16-EX-P-UNI		2904684 TC-2D37SUB-ADIO32-2EX-P-UNI					
Configuration	DIP switch							
Width	12.5 mm						17.5 mm	
Delivery state	Standard configuration							
Type	MACX MCR-EX-SL-NAM-R(-SP)		MACX MCR-EX-SL-NAM-2RO(-SP)		MACX MCR-EX-SL-2NAM-RO(-SP)		MACX MCR-EX-SL-2NAM-R-UP(-SP)	
Connection method	Push-in connection	Screw connection	Push-in connection	Screw connection	Push-in connection	Screw connection	Push-in connection	Screw connection
Item no.	2924045	2865434	2924061	2865450	2924087	2865476	2924249	2865984

The module can be snapped onto the DIN rail bus connector for 24 V voltage bridging

Wide range input for worldwide supply networks

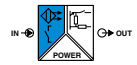



# Product overview – MACX Analog for explosion protection

Digital IN						
						
<b>Product type</b>	Isolation switch amplifier					
						
<b>Description</b>	Ex i NAMUR isolation switch amplifier		Ex i NAMUR isolation switch amplifier, 2-channel		Ex i NAMUR isolation switch amplifier, output with resistive behavior, with line fault transparency	
<b>Approvals</b>						
<b>Ex installation / Ex i switching circuit</b>	Gc; Div. 2 / Ga; Da; Ma; Div. 1					
<b>Functional safety</b>	SIL 2 / SC 3					
<b>Usable input source</b>	NAMUR proximity sensors (IEC/EN 60947-5-6) / floating circuit contacts / switch contacts with resistance circuit					
<b>Switching output</b>	Transistor output (passive)					
<b>Supply voltage</b>	19.2 V DC ... 30 V DC				9.6 V DC ... 30 V DC	
<b>Ambient temperature range</b>	-40°C ... +60°C (+70°C: derating)					
<b>Fault signaling: LED</b>	Yes					
<b>Fault monitoring</b>	Wire break / short circuit / device error					
<b>Termination Carrier (optional)</b>	2904684 TC-2D37SUB-ADIO32-2EX-P-UNI				2924854 TC-D37SUB-ADIO 16-EX-P-UNI	
<b>Configuration</b>	DIP switch					
<b>Width</b>	12.5 mm					
<b>Delivery state</b>	Standard configuration					
<b>Type</b>	MACX MCR-EX-SL-NAM-2T(-SP)		MACX MCR-EX-SL-2NAM-T(-SP)		MACX MCR-EX-SL-NAM-NAM(-SP)	
<b>Connection method</b>	Push-in connection	Screw connection	Push-in connection	Screw connection	Push-in connection	Screw connection
<b>Item no.</b>	2924074	2865463	2924090	2865489	2924883	2866006

# Product overview – MACX Analog for explosion protection

1  
2  
3







Signal conditioners and measuring transducers

Digital IN			
			
<b>Product type</b>	Relay module		
			
<b>Description</b>	Ex i relay module, 2-channel		
			
<b>Approvals</b>			
<b>Ex installation / Ex i switching circuit</b>	Gc / Ga; Da; Ma		
<b>Functional safety</b>	SIL 2		
<b>Input signal</b>	12 V ... 31.2 V (switching signal)		
<b>Switching output</b>	Relay output (1 changeover contact per channel)		
<b>Supply voltage</b>	Loop-powered, no external supply necessary		
<b>Ambient temperature range</b>	-20°C ... +70°C		
<b>Fault signaling: LED</b>	No		
<b>Width</b>	17.5 mm		
<b>Delivery state</b>	Standard configuration		
<b>Type</b>	MACX MCR-EX-AP-2REL-2DI-LP(-SP)		
<b>Connection method</b>	<table border="1" style="width: 100%;"> <tr> <td style="width: 50%; text-align: center;">Push-in connection</td> <td style="width: 50%; text-align: center;">Screw connection</td> </tr> </table>	Push-in connection	Screw connection
Push-in connection	Screw connection		
<b>Item no.</b>	<table border="1" style="width: 100%;"> <tr> <td style="width: 50%; text-align: center;">1292332</td> <td style="width: 50%; text-align: center;">1292331</td> </tr> </table>	1292332	1292331
1292332	1292331		

 The module can be snapped onto the DIN rail bus connector for 24 V voltage bridging

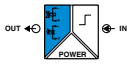
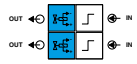
 Wide range input for worldwide supply networks



# Product overview – MACX Analog for explosion protection

Digital OUT								
								
Product type	Solenoid driver							
								
Description	Ex i solenoid driver, with logic input and line fault detection, current limitation at 25 mA		Ex i solenoid driver, with logic input and line fault detection, current limitation at 48 mA		Ex i solenoid driver, 2-channel, loop-powered, current limitation at 35 mA			
Approvals								
Ex installation / Ex i switching circuit	Gc; Div. 2 / Ga; Da; Ma; Div. 1				Gc / Ga; Da; Ma			
Functional safety	SIL 3							
Input signal	Switching level "0" signal: 0 V DC ... 5 V DC (or open) / Switching level "1" signal: 15 V DC ... 30 V DC				Switching level "0" signal: 0 V ... 5 V / Switching level "1" signal: 18 V ... 31.2 V			
Output signal	Output voltage: $\geq 4.64$ V DC (25.1 mA) / no-load voltage: $> 21.1$ V DC / current limitation: $> 25.1$ mA (with line fault detection)		Output voltage: $\geq 9.7$ V DC (48 mA) / no-load voltage: $> 24.3$ V DC / current limitation: $> 48$ mA (with line fault detection)		Output voltage: $\geq 9.36$ V DC (48 mA) / no-load voltage: $> 22.5$ V DC / current limitation: $> 48$ mA (with line fault detection)		Output current: $\leq 35$ mA (per output); $\leq 70$ mA (outputs connected in parallel) / no-load voltage: 25 V DC	
Supply voltage	19.2 V DC ... 30 V DC				loop-powered, no external supply necessary			
Ambient temperature range	-20°C ... +60°C (+70°C: derating)				-20°C ... +70°C			
Fault signaling: LED	Yes				No			
Fault monitoring	Wire break / short circuit / device error							
Termination Carrier (optional)	<a href="#">2924854</a> TC-D37SUB-ADIO16-EX-P-UNI							
Configuration	DIP switch							
Width	12.5 mm				17.5 mm			
Delivery state	Standard configuration							
Type	MACX MCR-EX-SL-SD-21-25-LFD(-SP)		MACX MCR-EX-SL-SD-24-48-LFD(-SP)		MACX MCR-EX-SL-SD-23-48-LFD(-SP)		MACX MCR-EX-AP-2SD-25-35-LP(-SP)	
Connection method	Push-in connection	Screw connection	Push-in connection	Screw connection	Push-in connection	Screw connection	Push-in connection	Screw connection
Item no.	<a href="#">2905674</a>	<a href="#">2905669</a>	<a href="#">2906156</a>	<a href="#">2906155</a>	<a href="#">2924870</a>	<a href="#">2924867</a>	<a href="#">1291186</a>	<a href="#">1291176</a>

# Product overview – MACX Analog for explosion protection

1  
2  
3

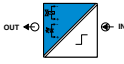
Signal conditioners and measuring transducers

Digital OUT									
									
<b>Product type</b>		Solenoid driver							
									
<b>Description</b>		Ex i solenoid driver, loop-powered, current limitation at 25 mA		Ex i solenoid driver, loop-powered, current limitation at 40 mA		Ex i solenoid driver, loop-powered, current limitation at 48 mA		Ex i solenoid driver, loop-powered, current limitation at 58 mA	
<b>Approvals</b>									
<b>Ex installation / Ex i switching circuit</b>		Gc; Div. 2 / Ga; Da; Ma; Div. 1							
<b>Functional safety</b>		SIL 3							
<b>Input signal</b>		19.2 V DC ... 30 V DC / 45 mA (Ue = 24 V DC)		19.2 V DC ... 30 V DC / 65 mA (Ue = 24 V DC)		19.2 V DC ... 30 V DC / 85 mA (Ue = 24 V DC)		19.2 V DC ... 30 V DC / 95 mA (Ue = 24 V DC)	
<b>Output signal</b>		Output voltage: $\geq 5.5$ V DC (25 mA) / no-load voltage: $> 21.9$ V DC / current limitation: $> 25$ mA		Output voltage: $\geq 10$ V DC (40 mA) / no-load voltage: $> 21.9$ V DC / current limitation: $> 40$ mA		Output voltage: $\geq 10.5$ V DC (48 mA) / no-load voltage: $> 24$ V DC / current limitation: $> 48$ mA		Output voltage: $\geq 12.9$ V DC (58 mA) / no-load voltage: $> 21.9$ V DC / current limitation: $> 58$ mA	
<b>Supply voltage</b>		Loop-powered, no external supply necessary							
<b>Ambient temperature range</b>		-40°C ... +60°C (+70°C: derating)							
<b>Fault signaling: LED</b>		No							
<b>Termination Carrier (optional)</b>		2924854 TC-D37SUB-ADIO16-EX-P-UNI							
<b>Width</b>		12.5 mm							
<b>Delivery state</b>		Standard configuration							
<b>Type</b>		MACX MCR-EX-SL-SD-21-25-LP(-SP)		MACX MCR-EX-SL-SD-21-40-LP(-SP)		MACX MCR-EX-SL-SD-24-48-LP(-SP)		MACX MCR-EX-SL-SD-21-60-LP(-SP)	
<b>Connection method</b>		Push-in connection	Screw connection	Push-in connection	Screw connection	Push-in connection	Screw connection	Push-in connection	Screw connection
<b>Item no.</b>		2924113	2865492	2924139	2865764	2924126	2865609	2924100	2865515

 The module can be snapped onto the DIN rail bus connector for 24 V voltage bridging

 Wide range input for worldwide supply networks

## System components and accessories

Supply the active 24 V signal conditioners via the connection terminal blocks or use the modular DIN rail bus connector as a flexible system solution for power bridging. Especially in multi-channel applications, the DIN rail bus connector simplifies installation, system expansion, and module replacement, even during operation. Additional accessories, such as programming adapters and feed-through terminal blocks, round off the portfolio.

COMPLETE line

Push-in Technology   
Designed by Phoenix Contact

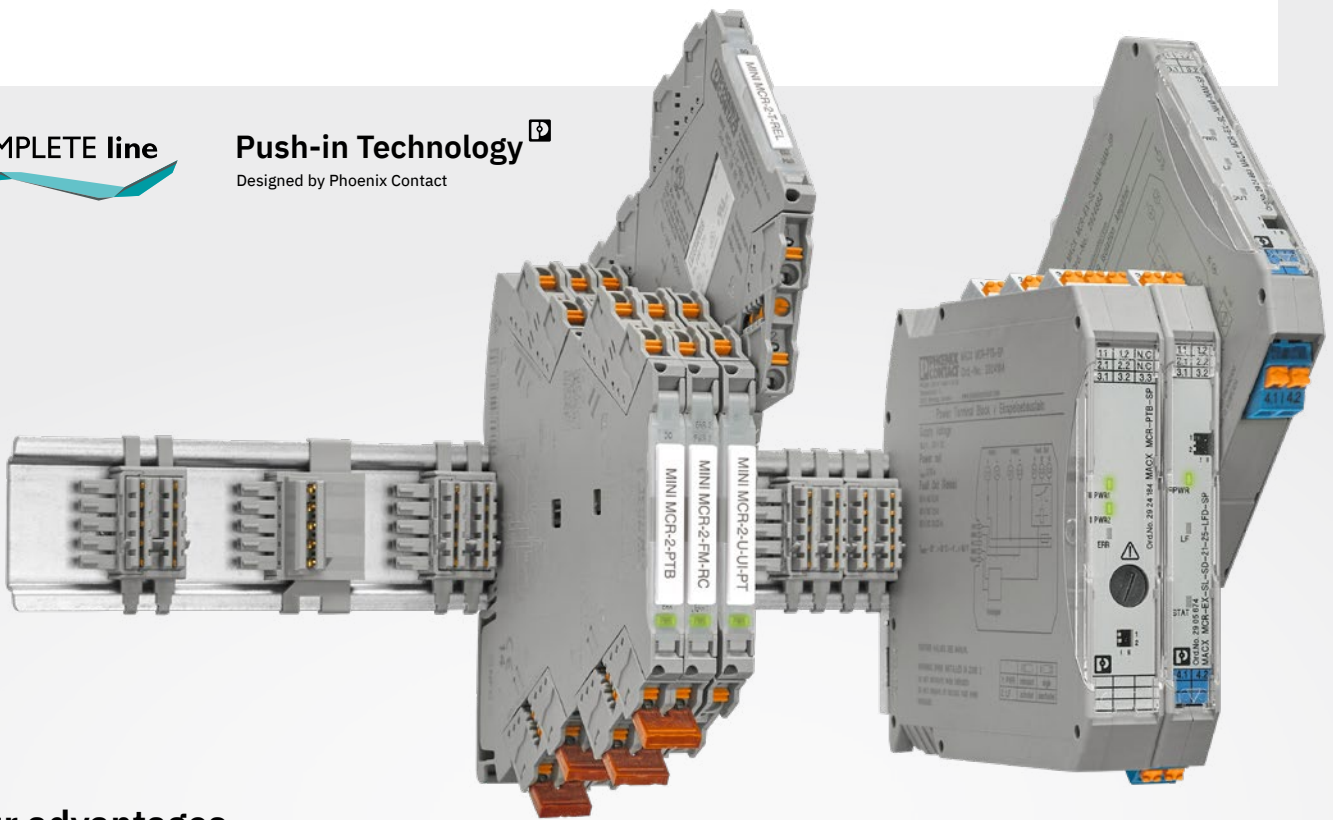

### Your advantages

- ✓ The DIN rail bus connector simplifies power bridging, system expansion, and module replacement
- ✓ Flexible supply options: a) direct feed-in, b) via a feed-in module, or c) via a system power supply with wide range input
- ✓ Convenient diagnostics with the MINI Analog Pro fault monitoring module or the MACX Analog power and fault signaling module
- ✓ Easy adaptation to the Pepperl+Fuchs supply system with the Power Rail adapter

# Your advantages in detail

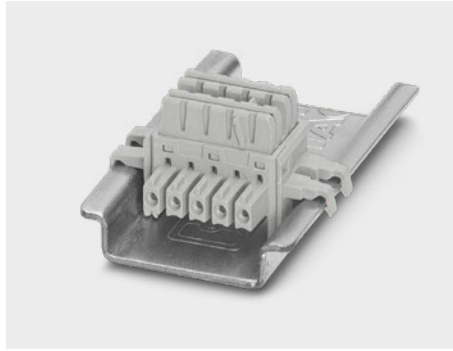
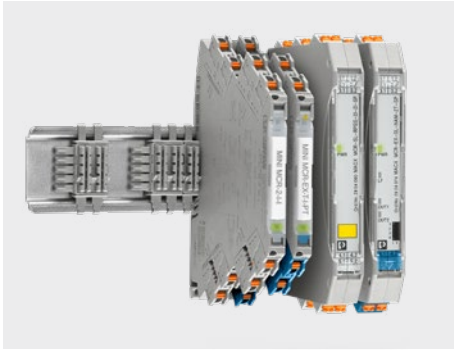

## Two families, one system

The TBUS DIN rail bus connector is compatible with the MINI Analog Pro and MACX Analog product families. This enables you to use the following types of power supply:

- Direct feed-in via the device-internal supply input
- Feed-in via a separate feed-in module
- Supply via a system power supply with wide range input

## Robust and safe

All components of the supply system are mechanically protected against contact. The contact elements are located in a robust plastic housing. In addition, the DIN rail bus connector features coding as well as an aid for error-free and quick insertion of the modules.

## System power supply

QUINT POWER power supplies are small in size yet ensure high system availability in the sub 100 W power range. This power supply, which has been developed specifically for MCR technology, enables the signal conditioners to be supplied directly from a 230 V AC supply via the TBUS DIN rail bus connector. Simply snapped onto the TBUS, it delivers a maximum current of 2.5 A.

## Easy adaptation to external supply systems

Ideal for system extensions and retrofit installations: the Power Rail adapter for the Pepperl+Fuchs supply system.

The Power Rail adapter enables the MINI Analog Pro and MACX Analog product families to be used as an alternative in existing installations with the Pepperl+Fuchs Power Rail.

A tight fit on the Power Rail and mechanical coding ensure secure and vibration-resistant contacting. Installation in zones up to Ex zone 2 possible.

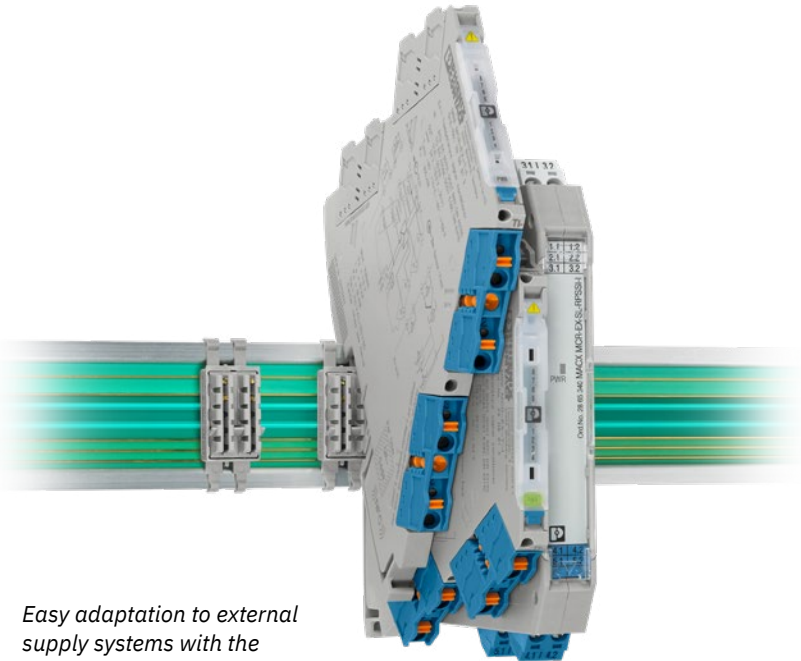

*Easy adaptation to external supply systems with the power rail adapter*

# Power supply and diagnostics

## Flexible feed-in

The DIN rail bus connector gives you three device supply options:

### Direct feed-in on the module

- Without additional accessories
- For up to 16<sup>1)</sup> MINI Analog Pro modules
- For up to 32<sup>1)</sup> MACX Analog modules

### Feed-in via a feed-in module of the same shape

- Also enables redundant supply and supply monitoring
- For up to 115<sup>1)</sup> MINI Analog Pro modules
- For up to 80<sup>1)</sup> MACX Analog modules

### Feed-in via the system power supply

- Also enables redundant supply and supply monitoring
- For up to 60<sup>1)</sup> MINI Analog Pro modules
- For up to 10<sup>1)</sup> MACX Analog modules

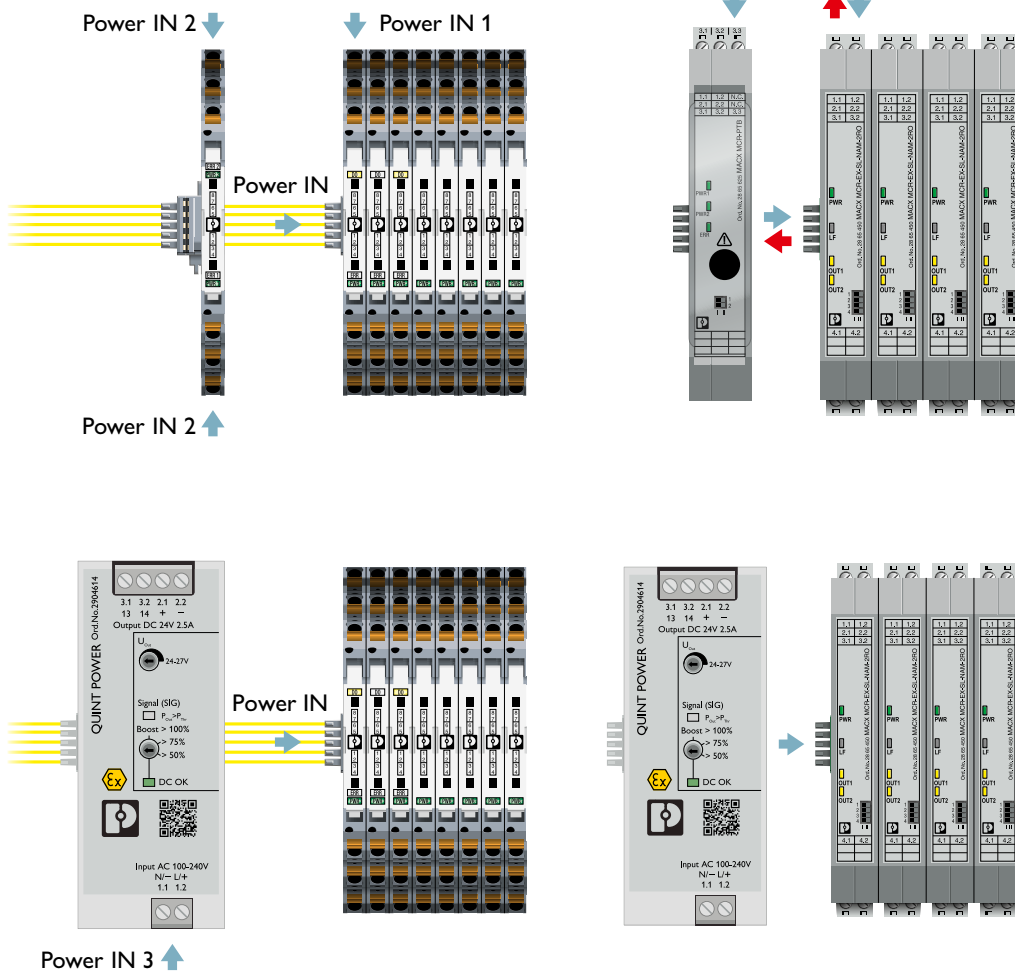

<sup>1)</sup> The exact number depends on the current consumption of the module type in question. Notes on calculation can be found in our feed-in manual in the download area for the item.

## Convenient diagnostics with fault monitoring group error messaging

With group error messaging fault monitoring, the DIN rail bus connector offers a modular solution for fast error evaluation in multi-channel applications. The MINI Analog Pro and MACX Analog systems are compatible with one another.

The following faults are indicated depending on the module type:

- Wire break
- Short circuit
- Supply failure
- Over-range or under-range (MINI Analog Pro only)
- Fuse fault on the feed-in module (MACX Analog only)

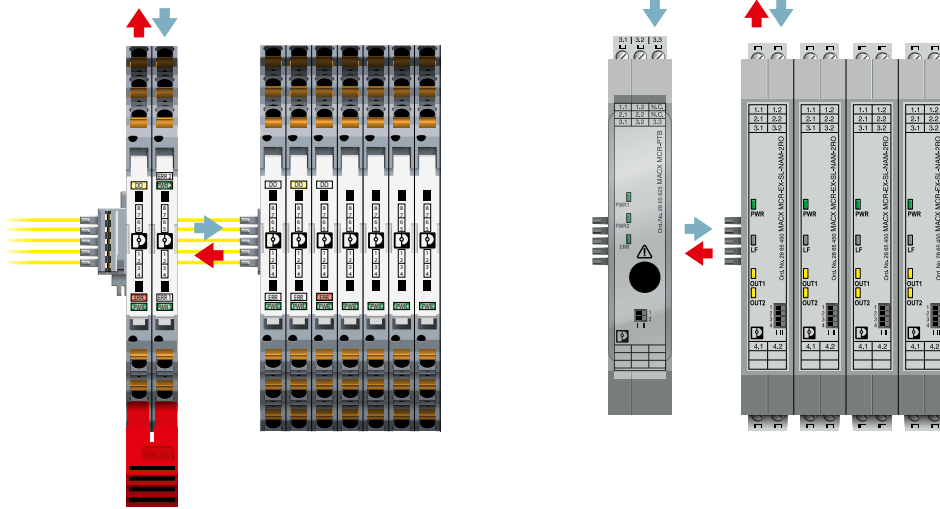

# Product overview – system components and further accessories

System components and accessories				
	Description	Connection method	Item no.	Type
	Primary-switched power supply, QUINT POWER. DIN rail mounting, supply of devices via the TBUS DIN rail connector possible, protective coating, Input: single-phase, output: 24 V DC / 2.5 A	Screw connection	2904614	QUINT4-SYS-PS/1AC/24DC/2.5/SC
	MCR power terminal for supplying several MINI Analog modules via the DIN rail bus connectors, current consumption up to max. 2 A	Screw connection	2864134	MINI MCR-SL-PTB
	The MINI MCR-SL-PTB-FM(-SP) power terminal is used to feed in the supply voltage to the DIN rail bus connector. The FM power terminal offers the additional function of monitoring in combination with the fault monitoring module.	Screw connection	2902958	MINI MCR-SL-PTB-FM
	The fault monitoring module is used to evaluate and report group errors from the fault monitoring system and monitor supply voltages. The error is reported via an N/O contact. Standard configuration.	Screw connection	2902961	MINI MCR-SL-FM-RC-NC
	Feed-through terminal block with plug-in connection technology for the transmission of signals that are already electrically isolated.	Screw connection	2902068	MINI MCR-2-TB
	Power terminal with plug-in connection technology for feeding the supply voltage to the DIN rail bus connector. Monitoring of the supply voltages in combination with the fault monitoring module.	Push-in connection	2902067	MINI MCR-2-PTB-PT
		Screw connection	2902066	MINI MCR-2-PTB
	Fault monitoring module with plug-in connection technology for evaluating and reporting group errors from the FM system and for monitoring the supply voltages. Error message via N/C contact. Standard configuration	Push-in connection	2904508	MINI MCR-2-FM-RC-PT
		Screw connection	2904504	MINI MCR-2-FM-RC
	Power and fault signaling module, including the relevant DIN rail bus connector ME 17,5 TBUS 1,5/ 5-ST-3,81 GY	Push-in connection	2924184	MACX MCR-PTB-SP
		Screw connection	2865625	MACX MCR-PTB
	Dummy module with no function for connecting unused intrinsically safe signal cables.	Push-in connection	2905846	MACX MCR-EX-DUMMY-ISOLATOR-SP
		Screw connection	2904970	MACX MCR-EX-DUMMY-ISOLATOR











# Product overview – system components and further accessories

1

2

3

Signal conditioners and measuring transducers

System components and accessories			
	Description	Item no.	Type
	DIN rail bus connector (TBUS), 5-pos., for bridging the supply voltage, can be snapped onto NS 35/... DIN rail in accordance with EN 60715	2695439	ME 6,2 TBUS-2 1,5/5-ST-3,81 GY
	DIN rail bus connector for DIN rail mounting. Universal for TBUS housing. Gold-plated contacts, 5-pos.	2869728	ME 6,2 TBUS-2 1,5/5-ST-3,81 GN
	DIN rail bus connector, color: gray, nominal current: 8 A (parallel contacts), rated voltage (III/2): 125 V, number of positions: 5, item family: TBUS5-17,5..., pitch: 3.81 mm, mounting: DIN rail mounting, locking: without, fastening type: without, packaging: packed in a carton, item with gold-plated contacts, bus connector for connecting to electronics housings, 5 parallel contacts	1090049	ME 17,5 TBUS 1,5/ 5-ST-3,81 GY
	End bracket, robust design for DIN rail bus connectors	2713780	E/ME TBUS NS35 GY
	Programming adapter with USB interface, for programming with software. The USB driver is included in the software solutions for the products to be programmed, such as measuring transducers and motor managers.	2811271	IFS-USB-PROG-ADAPTER
	Bluetooth adapter with micro USB and S-PORT interface for wireless communication with the MINI Analog, MINI Analog Pro, MACX Analog, Interface System Gateways, and PLC logic device series.	2905872	IFS-BT-PROG-ADAPTER
	Near Field Communication (NFC) programming adapter with USB interface for the wireless configuration of NFC-capable products from Phoenix Contact with software. A separate USB driver is not required.	2909681	TWN4 MIFARE NFC USB ADAPTER
	Power rail adapter (ME 6,2 TBUS-PR-ADAPTER), 2-pos., enables MINI and MACX Analog modules to be adapted for supply via universal power rail UPR-03 and UPR-05.	1136500	ME 6,2 TBUS-PR-ADAPTER
	Setpoint value potentiometer, for specifying setpoints individually, resistance value 4.7 kΩ	2940252	EMG 30-SP- 4K7LIN
	Setpoint value potentiometer, for specifying setpoints individually, resistance value 10 kΩ	2942124	EMG 30-SP-10K LIN
	Setpoint potentiometer cascadable, for selecting preconfigurable setpoints via a 24 V control signal, resistance value 10 kΩ	2942137	EMG 30-SPK-10K LIN
	The partition plate is used to maintain Ex i isolating distances when Ex i and non-Ex i devices are mounted side by side on a DIN rail.	1430594	MCR-DP

# I/O signal marshalling

2

Phoenix Contact provides various solutions for your I/O signal routing in process automation. For classic I/O signal routing, our Termination Carrier provide you with a plug-and-play solution for connecting classic DIN rail devices to the standard I/O cards of your automation system. The VIP I/O marshalling signal marshalling system, which can be equipped flexibly, makes I/O signal marshalling for universal I/O consistent, from the field to the controller.

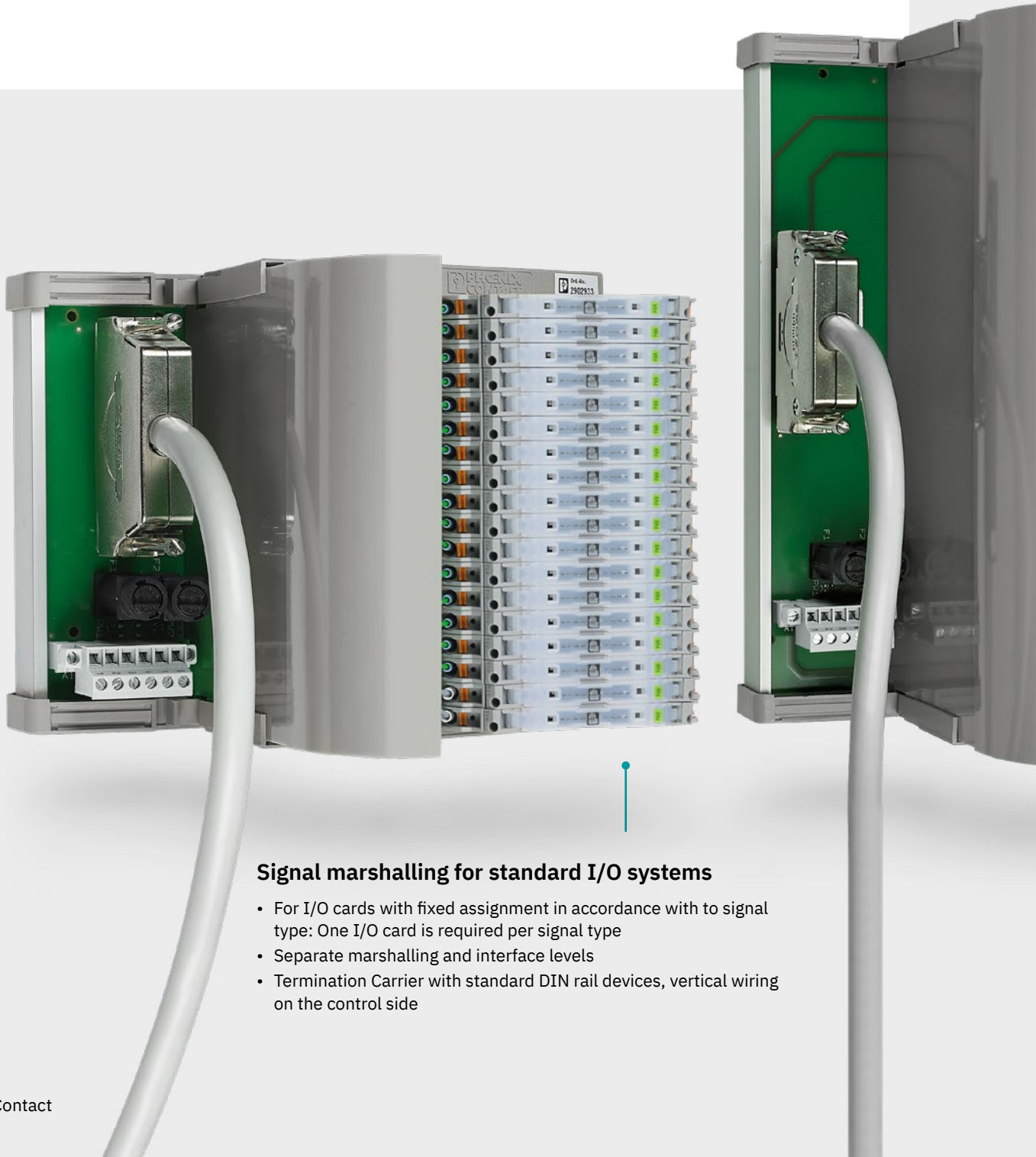

## Signal marshalling for standard I/O systems

- For I/O cards with fixed assignment in accordance with to signal type: One I/O card is required per signal type
- Separate marshalling and interface levels
- Termination Carrier with standard DIN rail devices, vertical wiring on the control side

## Signal marshalling for universal I/O systems

- For universal I/O cards with flexible channel assignment: one I/O card for all signal types
- Combined marshalling and interface level
- Pluggable input-output accessories, upright wiring on field and control side



# Signal marshalling in comparison

	Standard I/O signal marshalling	Universal I/O signal marshalling
<b>Control input</b>	<p>Standard I/O boards</p> <ul style="list-style-type: none"> <li>A separate I/O board is required for each signal type, e.g., for AI, AO, DI, DO, temperature...</li> <li>Five signal types mean five I/O boards</li> <li>8 / 16 / 32 channels per board</li> <li>Unnecessary channels take up space and result in additional costs</li> </ul>	<p>Universal I/O boards</p> <ul style="list-style-type: none"> <li>I/O boards with flexible channel assignment for AI, AO, DI, DO, temperature...</li> <li>Five signal types mean one I/O board</li> <li>Channel assignment specified via software</li> </ul>
<b>Signal marshalling</b>	<p>Separate marshalling level</p> <ul style="list-style-type: none"> <li>Incoming field signals are sorted by signal type</li> <li>The marshalling level is then wired to the interface level</li> </ul>	<p>Universal remote cabinets</p> <ul style="list-style-type: none"> <li>Marshalling and interface levels are combined in decentralized control boxes</li> <li>Incoming field signals are arbitrarily routed to the input terminal blocks of the universal I/O system</li> <li>No need to sort the field signals by signal type (except for Safety/Ex i)</li> </ul>
<b>Signal processing</b>	<p>Separate interface level with Termination Carriers</p> <ul style="list-style-type: none"> <li>One Termination Carrier is required per signal type, with 8/16/32/ etc. channels</li> <li>Termination board assembly is determined by the signal type</li> <li>Unnecessary channels take up space and result in additional costs</li> </ul>	<p>Universal I/O systems</p> <ul style="list-style-type: none"> <li>Flexible configuration and assembly of channels with input/output accessories (IOAs) that have various interface functions</li> </ul>

## Signal marshalling for standard I/O systems

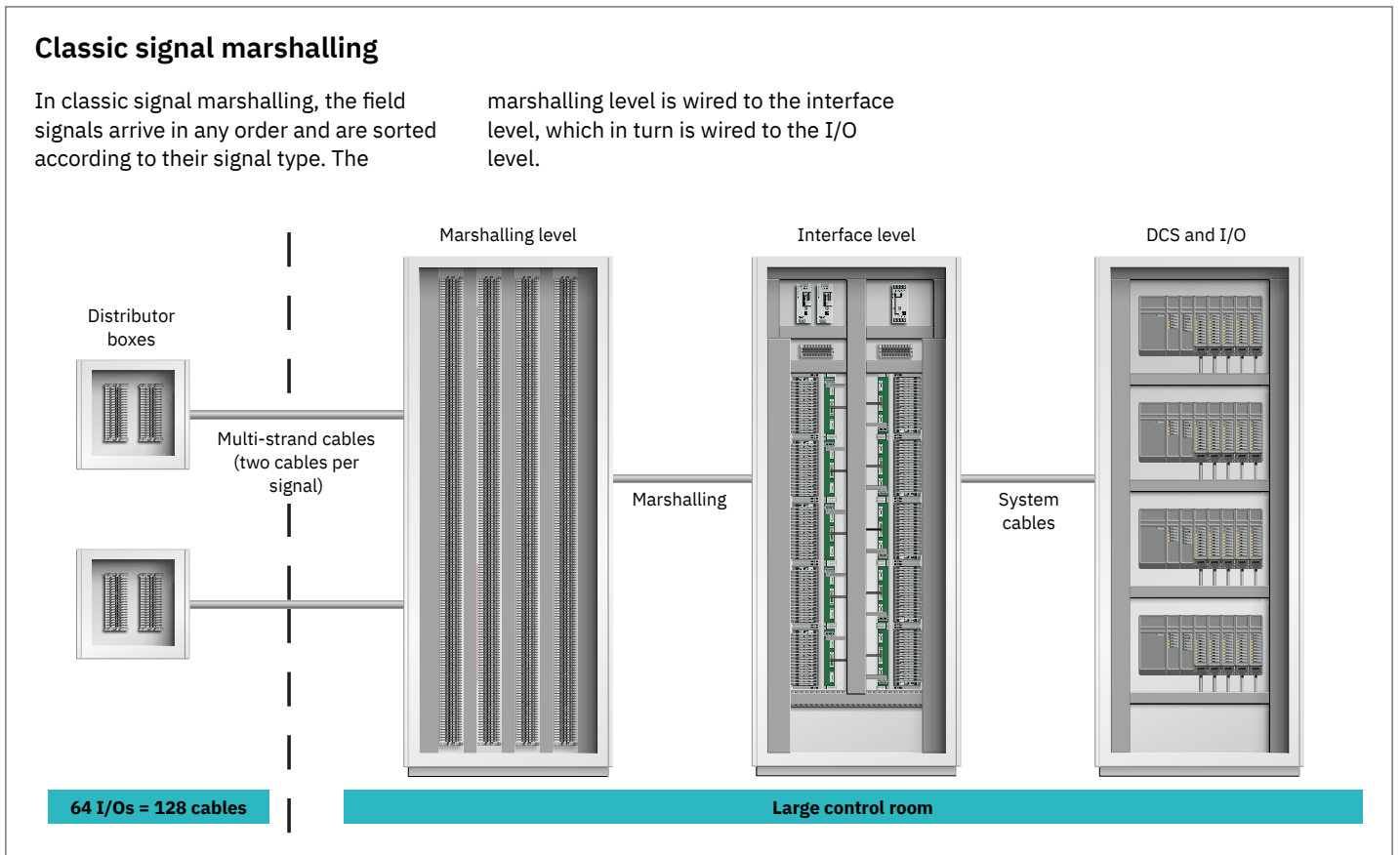

# Signal marshalling for universal I/O systems

## Universal remote cabinet with VIP I/O marshalling

With universal remote cabinets, the need for large marshalling and interface cabinets is eliminated. The field signals are routed directly to the VIP I/O

marshalling base elements in the control cabinets. The connection to the universal I/O system is then made using the system cable. The final connection to the

control system is established via a single fiberglass cable.

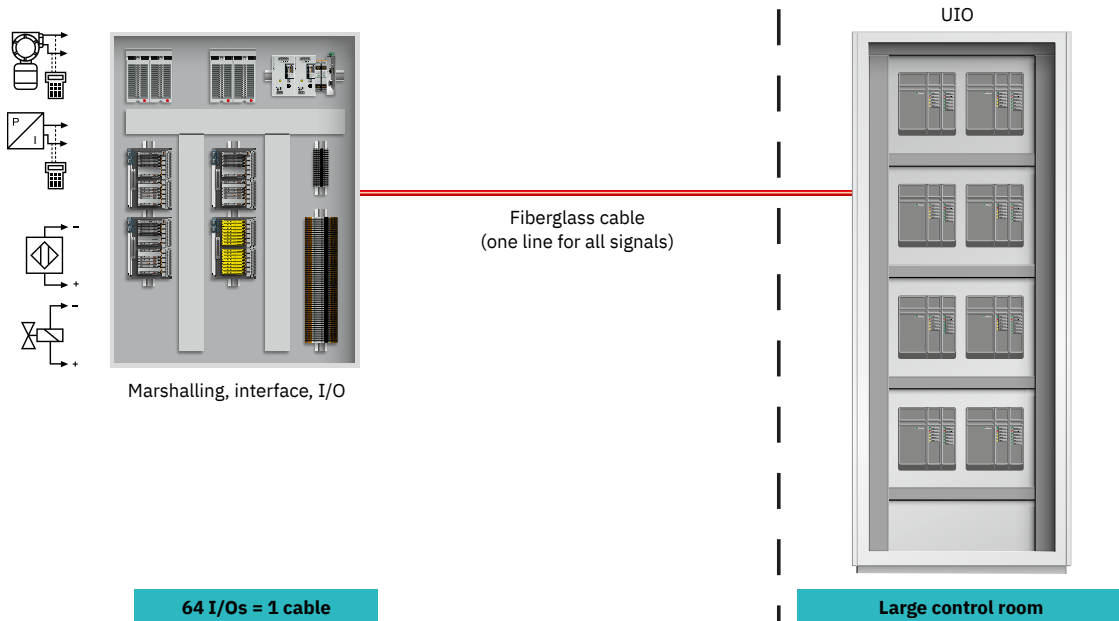

## Full flexibility on the interface and marshalling level

Depending on the size of the plant, several thousand signals must be marshalled between the field and control levels to control a continuous process in process engineering plants. Conventional solutions, such as interface blocks mounted on the DIN rail, however, require the exact signal type to be known at an early stage. Moreover, signals need to be marshalled again in the process in order to wire the field signals to the individual function blocks, such as to relays for digital output signals.

With the universal I/O approach on the control level, you already achieve improvements here compared to the classic signal marshalling. Instead of the 8/16/32/64-channel blocks for each signal type, with Universal I/O cards you use software to adapt the individual channels to the necessary function. The flexible I/O marshalling system VIP I/O marshalling has been specially designed for use on Universal I/O systems. The solution offers the same flexibility at the

interface and marshalling level as the universal I/O systems at the I/O level.

### Pluggable input/output accessories with various interface functions

The optional plug-in input-output accessories (IOAs) are blocks with various electrical functions for signal processing. This is universal marshalling – from the field to the controller.

The following IOAs are available:

- Passive modules
- Relays
- Safety relays
- Signal conditioners
- Measuring transducers
- Fuse modules
- Special functions

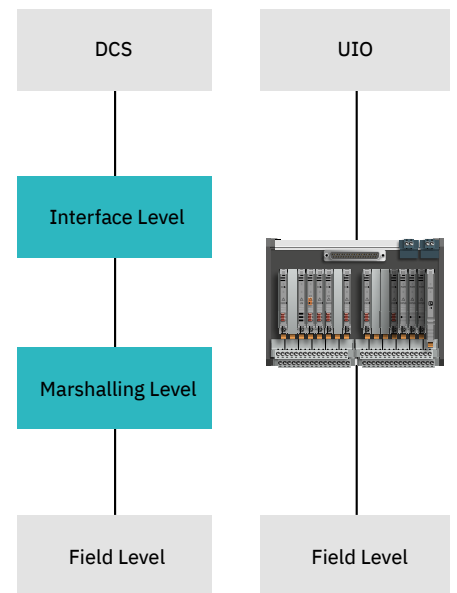

*VIP I/O marshalling makes universal I/O truly universal – from the field to the controller*

## Signal marshalling for standard I/O systems

Our compact and robust Termination Carriers are plug-and-play solutions for fast and error-free connection of a large number of signals from the field to your automation system. By using standard DIN rail devices, you only need one engineering design for standard DIN rail and system applications.



### Your advantages

- ✔ Space-saving due to the compact design
- ✔ High system availability with the robust housing with mechanically decoupled termination PCB
- ✔ Simple wiring with pluggable, coded cable sets and preassembled system cables
- ✔ Optimum adaptation with a variety of system connectors and front adapters for the I/O cards of various automation systems
- ✔ Service-friendly due to hot-swap module replacement and easily accessible connection elements

# Your advantages in detail



## High system availability

The stable, vibration-proof aluminum carrier has a profile for accommodating standard DIN rail devices. In addition, the termination PCB is mechanically decoupled. The passive design of the termination PCB provides additional failsafe performance: it does not contain any active components.

## Easy installation and engineering

Easily accessible terminal points and hot-swap module replacement allow you to perform installation servicing more easily. You can connect the products to the Termination Carrier PCB quickly and safely with pluggable and coded cable sets. By using standard DIN rail devices, you only need one engineering design for standard DIN rail and system applications.

## Optimum adaptation

Pitch-free profile lengths and a wide range of system connectors and front adapters allow you to adapt optimally to the I/O cards of various automation systems. In addition to the universal Termination Carriers with 1:1 pinning and optional HART® signal decoupling, various control system-specific versions are available.

## The space-saving solution for low signal volumes

The MINI Analog Pro system adapter provides you with a time-saving plug-and-play wiring solution. The easily pluggable system adapter lets you connect eight MINI Analog Pro signal conditioners in any combination to your controller quickly and error-free.

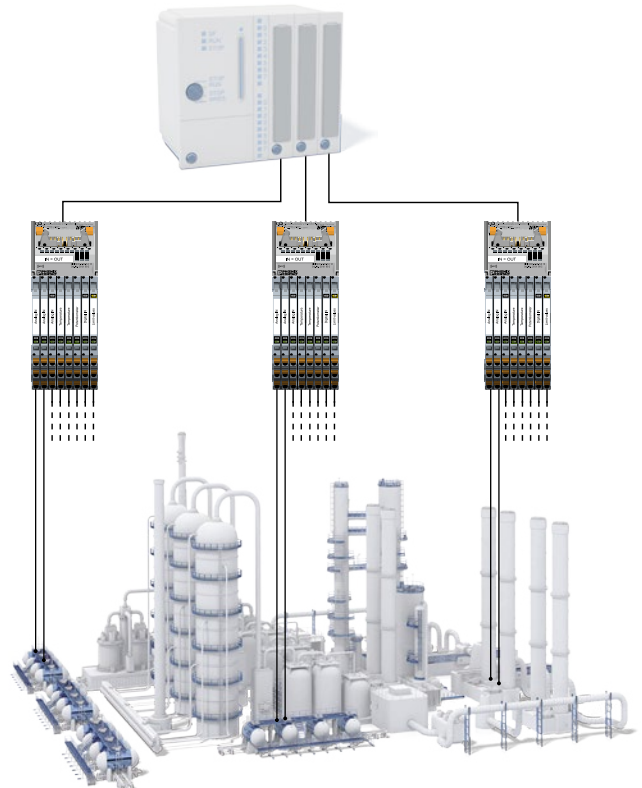



# Product overview – Termination Carriers for standard I/O systems



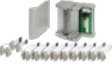

## Your individual solution

In addition to our universal Termination Carriers, we also provide solutions for the I/O boards of various controller manufacturers.

Please contact us for more information.



Termination Carrier for MINI Analog Pro signal conditioners				
	Description	Item no.	Type	
	Universal Termination Carrier for connecting 16 MINI Analog Pro signal conditioners to digital or analog I/O cards, via D-SUB connector, 37-pos. (1:1 connection)	2906639	TC-D37SUB-ADIO16-MP-P-UNI	
	Universal Termination Carrier for connecting 16 MINI Analog Pro signal conditioners to digital or analog I/O cards, via D-SUB connector, 37-pos. (1:1 connection), with HART multiplexer connection	2906640	TC-D37SUB-AIO16-MP-PS-UNI	

Accessories				
	Description	Connection method	Item no.	Type
	Feed-through terminal block with plug-in connection technology for the transmission of signals that are already electrically isolated.	Screw connection	2902068	MINI MCR-2-TB
	Power terminal with plug-in connection technology for feeding the supply voltage to the DIN rail bus connector. Monitoring of the supply voltages in combination with the fault monitoring module.	Push-in connection	2902067	MINI MCR-2-PTB-PT
		Screw connection	2902066	MINI MCR-2-PTB
	Fault monitoring module with plug-in connection technology for evaluating and reporting group errors from the FM system and for monitoring the supply voltages. Error message via N/C contact. Standard configuration	Push-in connection	2904508	MINI MCR-2-FM-RC-PT
		Screw connection	2904504	MINI MCR-2-FM-RC
	HART multiplexer for the online configuration and diagnostics of HART-compatible field devices as well as the continuous documentation of process variables and states using a PC or management system, for mounting on NS 35/7.5 or NS 32	Flat-ribbon cable, 14-pos. (included) (HART FSK) / D-SUB 9 female connector (RS-485)	2865599	MACX MCR-S-MUX



## Product overview – Termination Carriers for standard I/O systems

1

2

3

I/O signal marshalling

Termination Carrier for MACX Analog signal conditioners with functional safety and explosion protection			
	Description	Item no.	Type
	Universal Termination Carrier for connecting 16 MACX Analog Ex i signal conditioners to digital or analog I/O cards, via D-SUB connector, 37-pos. (1:1 connection)	2924854	TC-D37SUB-ADIO16-EX-P-UNI
Accessories			
	Description	Item no.	Type
	Power and fault signaling module with screw connection, only for use on the Termination Carrier, excluding corresponding DIN rail bus connector	2904673	TC-MACX-MCR-PTB
	Cable set for signal transmission and power supply on the Termination Carrier for signal conditioners from the MACX Analog Ex series. Connection of terminal points 3.2 and 2.2 (signal transmission for active input cards) to the signal PCB.	2904446	TC-C-MAX2-SC-32220000

# Product overview – Termination Carriers for standard I/O systems

## PSR safety relays

Our TÜV-certified SIL coupling relays for safe switch-on and switch-off enable the electrical isolation of signals up to SIL 3. System downtimes can be reduced to a minimum by diagnostic functions, such as integrated proof test and line load monitoring. The SIL 3 coupling relays with ATEX, G3 coating, and temperature range up to +70°C are suitable for special applications in the process industry.

### PSRmini



- Overall widths of 6.8 mm, 12.5 mm, and 17.5 mm
- For safe switch-on and safe shutdown
- LEDs enable SIL-qualified diagnostics directly on the module
- One to three enabling current paths
- Active error feedback directly to the controller by DCS test pulse filters ensures short downtimes during planned maintenance phases

### PSRclassic

- Overall width from 17.5 mm
- SIL coupling relays for safe switch-off
- Three safe relay contacts and contact multiplication

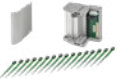

Termination carriers for highly compact PSR safe coupling relays			
	Description	Item no.	Type
	Universal Termination Carrier for connecting 16 MINI PSR SIL coupling relays to digital output cards, via D-SUB connector, 37-pos. (1:1 connection)	2906609	TC-D37SUB-DO16-PS-P-UNI

Accessories				
	Description	Connection method	Item no.	Type
	The fault monitoring module is used to evaluate and report group errors from the fault monitoring system and monitor supply voltages. The error is reported via an N/O contact. Standard configuration.	Screw connection	2902961	MINI MCR-SL-FM-RC-NC
	The MINI MCR-SL-PTB-FM(-SP) power terminal is used to feed in the supply voltage to the DIN rail bus connector. The FM power terminal offers the additional function of monitoring in combination with the fault monitoring module.	Screw connection	2902958	MINI MCR-SL-PTB-FM

Digital OUT				
	Description	Connection method	Item no.	Type
	Coupling relay for SIL 3 high and low-demand applications, couples digital output signals to the I/O, 1 enabling current path, 1 confirmation current path, safe-state-off applications, test pulse filter	Screw connection	2702524	PSR-PS22-1NO-1NC-24VDC-SC

# Product overview – Termination Carriers for standard I/O systems



1



2

3

I/O signal marshalling

PSR termination carriers for safe coupling relays			
	Description	Item no.	Type
	Universal Termination Carrier for redundantly connecting 16 PSR-FSP modules to digital output cards, via two D-SUB connectors, 37-pos. (1:1 connection). Solution for Emergency Shut Down (ESD) applications	2902913	TC-2D37SUB-DO16-ESD-AR-UNI

Digital OUT				
	Description	Connection method	Item no.	Type
	Safe coupling relay for SIL 3 high- and low-demand applications, couples digital output signals to the periphery, one enabling current path, one signal contact, module for safe-state-off applications, test pulse filter, fuse, width: 17.5 mm	Screw connection	2981978	PSR-SCP- 24DC/FSP/1X1/1X2
		Push-in connection	2981981	PSR-SPP- 24DC/FSP/1X1/1X2
	Safe coupling relay for SIL 2 high and low demand applications, couples digital output signals to the periphery, two enabling current paths, one signal contact, module for safe state off applications, integrated test pulse filter, width: 17.5 mm	Screw connection	2986575	PSR-SCP- 24DC/FSP2/2X1/1X2
	Safe coupling relay for SIL 3 high and low demand applications, couples digital output signals to the periphery, two enabling current paths, one signal contact, module for safe state off applications, integrated test pulse filter, width: 17.5 mm	Screw connection	2986960	PSR-SCP- 24DC/FSP/2X1/1X2

Accessories			
	Description	Item no.	Type
	Cable set for signal transmission on the Termination Carrier for coupling relays from the PSR-FSP series. Connection of terminal points A1 and A2 (signal transmission) to the signal PCB. Suitable for PSR-SCP-24DC/FSP/1X1/1X2 (item no. 2981978).	2903389	TC-C-PSR3-SC-A10000A20000
	Cable set for signal transmission on the Termination Carrier for coupling relays from the PSR-FSP series. Connection of terminal points A1 and A2 (signal transmission) as well as 31 and 32 (confirmation). Suitable for PSR-SCP-24DC/FSP/2X1/1X2 (item no. 2986960) and PSR-SCP-24DC/FSP2/2X1/1X2 (item no. 2986575).	2903390	TC-C-PSR3-SC-A10000A23132
	Jumper plug, for looping through the checkback contacts of unused module slots. Use on the termination carrier for safety relay modules from the PSR-FSP series.	2903388	TC-C-PTSM-50-0000000J1J1

## Signal marshalling for universal I/O systems

Design your universal I/O marshalling system consistently from the field to the control level with the flexible I/O marshalling system: VIP I/O marshalling. The system combines signal marshalling and processing in a controller-independent solution for your universal I/O system. Pluggable input/output accessories with various interface functions enable universal configuration of individual channels.

COMPLETE line



### Your advantages

- ✔ Reduction of project times for signal type-independent planning and seamless universal I/O connection
- ✔ Fewer control cabinets, more signals per cabinet: marshalling and interface level in the compact board
- ✔ Plug-and-play configuration from various boards and plug-in modules
- ✔ Wide signal spectrum, with SIL, Ex i, and surge protection
- ✔ Flexible at all times: easy module replacement with standing wiring



## Your advantages in detail



### Simplified planning

Instead of the 8/16/32/64-channel blocks for each signal type, with universal I/O boards you use software to adapt the individual channels to the necessary function. This means that only the number of signals must be taken into account during planning. The signal type is adapted later.

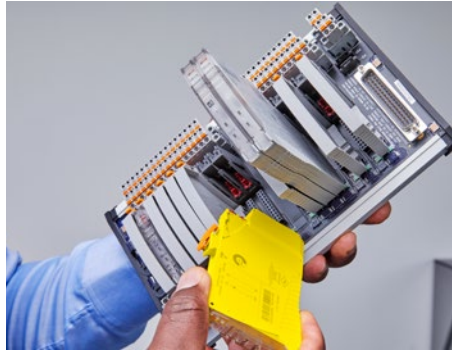

### Universal and reliable

From the simple terminal block, through relays, right up to signal conditioners with explosion protection and functional safety: The wide range of IOAs ensures that all types of signals from the field are reliably processed and transmitted to the control level. Plug-in capability and state-of-the-art signal processing technologies increase system availability and reduce downtimes.



### Reduces wiring effort, saves space

In distributed universal remote cabinets, field signals are applied directly to the base elements, processed, and connected to the universal I/O cards via system cable. Large marshalling and interface cabinets are no longer needed. Laborious cross-wiring is no longer necessary.

1

2

3

I/O signal marshalling

### Significant reduction in project lead times

The universal I/O concept, in combination with intelligent signal marshalling, offers significant advantages for planning and implementing complex process automation projects. Project information that was previously required at an early stage, such as the number of individual

field signal types, is now only required at a later stage of the project. This simplifies planning and procuring hardware. In addition, individual project steps can be processed in parallel due to the increased flexibility of the approach. Overall, this shortens project lead times significantly,

which also reduces total investment costs.

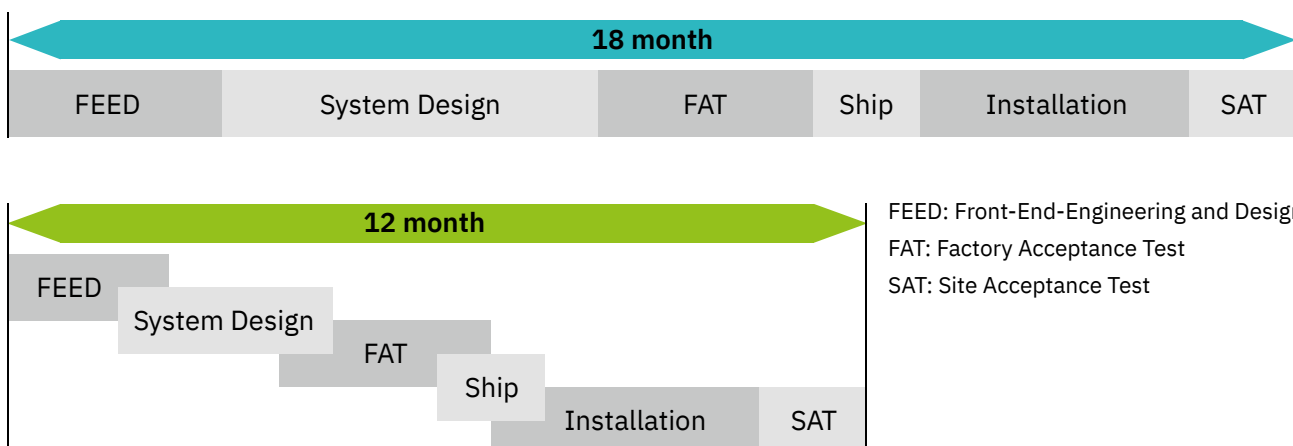



# Product overview – VIP I/O marshalling for universal I/O systems

## Base elements

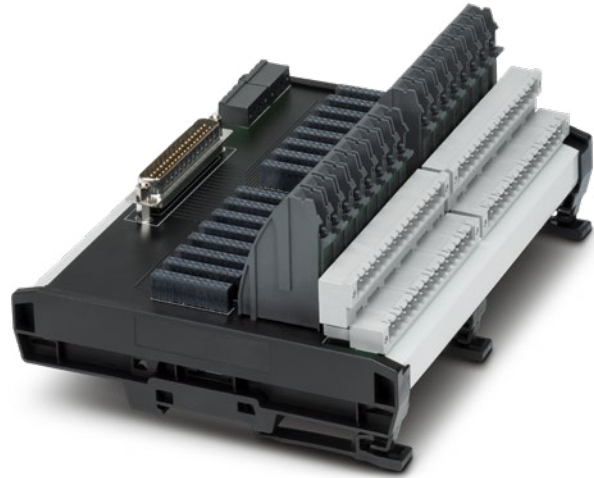
The robust base elements have 16 freely assignable slots for the function modules, so-called input-output accessories. The base elements are connected to the field wiring, transfers the field signals to the function modules and from there to the system cable. Choose between controller-specific and manufacturer-independent base elements.



Base elements			
	Description	Item no.	Type
	16-channel VIP I/O marshalling base element with 37-pos. D-SUB connector for universal use. Plug-in field and supply terminals available as accessories. With Push-in connection technology. For either Ex i or non-Ex.	1065476	BASE-MSTB/D37M/16CH/EX
	16-channel VIP I/O marshalling base element for universal use. Plug-in field and supply terminals available as accessories. With Push-in connection technology. Compatible with the Tricon CX DCS series (D-SUB 50).	2908788	VIP/MSTB/D50M/BASE/16CH/CX/EX

# Product overview – VIP I/O marshalling for universal I/O systems







## Accessories

Depending on the base element, connector sets with four or six connection terminal blocks per channel are available for the field connection, each with Push-in connection. The partition plates ensure a physical separation between field terminals and power bus terminals or power supply components on the VIP base module. You can also choose between fuse sets with different current

ratings. A wide range of standard and controller-specific system cables connects your base element to the respective I/O systems.



## Accessories

	Description	Item no.	Type
	Connector set for standard applications for use with BASE-MSTB/D37M/16CH/EX VIP I/O marshalling base element with Push-in connection.	1193570	PLUGKIT-GY/FKC/16CH-1-16
		1300532	PLUGKIT-BU/FKC/16CH-1-16
	Connector set for use with VIP/MSTB/D50M/BASE..., Push-in connections	2910417	VIP/P/FKC/KIT CX
	VIP I/O marshalling partition plate for safe isolation between Ex i plug-in modules and the power supply of the VIP/MSTB/D50M/BASE/16CH/CX/EX base module. The partition plate is mounted directly on the base module between the plug-in IOAs and the power supply.	2910139	VIP/UM-PRO/BASE DIVIDER/CX
	VIP I/O marshalling partition plate for safe isolation between non-Ex i and Ex i assembled base modules, for universal use in UM-PRO ...MSTB... design. The partition plate is mounted directly on the DIN rail at the end of the base module.	1267397	BASE/U/RAIL DIVIDER
	VIP I/O marshalling partition plate for safe isolation between non-Ex i and Ex i plug-in modules on a base module in VIP design. The partition plate is mounted directly on the base module between the plug-in IOAs.	2907715	VIP/S/BASE 3L DIVIDER
	Fuse set, quantity: 10 pieces, nominal current: 0.315 A, Tripping characteristic: slow-blow (T)	1192057	FUSE/TE5/315MA/T-10PCS
	Fuse set, quantity: 10 pieces, nominal current: 1 A, Tripping characteristic: slow-blow (T)	1053562	FUSE/TE5/1A/T-10PCS
	Fuse set, quantity: 10 pieces, nominal current: 2.5 A, Tripping characteristic: slow-blow (T)	1214124	FUSE/TE5/2.5A/T-10PCS
	Fuse set, quantity: 10 pieces, nominal current: 3.15 A, Tripping characteristic: slow-blow (T)	1053563	FUSE/TE5/3.15A/T-10PCS

# Product overview – VIP I/O marshalling for universal I/O systems

Accessories – cables	
	<p>VIP 16-channel cable for use with Honeywell C300 universal I/O</p>  <p>CAB-MSTB32/2XMC9/18/*M/C3/S</p>
Cable length	AWG 18 signal line
0.4 m	<a href="#">2908403</a>
0.5 m	<a href="#">2908404</a>
1 m	<a href="#">2908405</a>
2 m	<a href="#">2908406</a>
3 m	<a href="#">2908407</a>
4 m	<a href="#">2908408</a>
6 m	<a href="#">2908409</a>
8 m	<a href="#">2908410</a>
10 m	<a href="#">2908411</a>
15 m	<a href="#">2908412</a>
20 m	<a href="#">2908413</a>
25 m	<a href="#">1673565</a>

# Product overview – VIP I/O marshalling for universal I/O systems

## Analog IN



Repeater power supplies and input signal conditioners are used in a wide range of applications in the process industry. They supply passive field devices with the necessary power, amplify signals, and filter unwanted interfering signal from the measuring circuit. The IOAs are HART®-transparent and as an option have SIL and Ex i approval.

## Analog OUT



Analog output drivers are needed to drive a measuring signal from the controller into the field via a load. This is used, for example, to operate P/I converters, regulating valves, and displays. The IOAs are HART®-transparent and have SIL approval and, as an option, EX i approval.



### Analog IN

	Description	Item no.	Type
	Ex i repeater power supply and input signal conditioner, HART-transparent, for VIP I/O marshalling base elements: Transmits 0/4 mA ... 20 mA signals from the Ex area to a load (active or passive) in the safe area. 3-way electrical isolation, SIL 2, SC 3 in accordance with IEC 61508	1085761	IOA MCR-EX-RPSS-I-I
	Repeater power supply and input signal conditioner, HART-transparent, for VIP I/O marshalling base elements: Transmits 0/4 mA ... 20 mA signals to a load (active or passive). 3-way electrical isolation, SIL 2, SC 3 in accordance with IEC 61508	1085774	IOA MCR-RPSS-I-I

### Analog OUT





	Description	Item no.	Type
	Ex i output signal conditioner, HART-transparent, for VIP I/O marshalling base elements: Isolates and transmits 0/4 mA .... 20 mA signals with intrinsic safety to a load in the Ex area. 3-way electrical isolation, line fault detection, SIL 2, SC 3 in accordance with IEC 61508	1044642	IOA MCR-EX-IDS-I-I
	Output signal conditioner, HART-transparent, for VIP I/O marshalling base elements: Isolates and transmits 0/4 mA .... 20 mA signals to a load. 3-way electrical isolation, line fault detection, SIL 2, SC 3 in accordance with IEC 61508	1176865	IOA MCR-IDS-I-I

# Product overview – VIP I/O marshalling for universal I/O systems

## Digital IN

Binary input signals in the process industry are often simple switches or NAMUR proximity sensors. NAMUR isolation switch amplifiers operate these switches and transmit these signals out of the intrinsic safety area. IOA relay modules are used for the electrically isolated coupling of field devices (<230 V) to digital inputs. The IOAs are available with SIL and optionally with Ex i approval.



Digital IN			
	Description	Item no.	Type
	Relay module for VIP I/O marshalling base elements. For the electrically isolated coupling of 24 V DC field devices to digital inputs. Integrated fuse and fuse failure indication.	2910155	IOA REL 24V DI/BFI/1.0A/EX
	Relay module for VIP I/O marshalling base elements. For the electrically isolated coupling of 120 V AC field devices to digital inputs. Integrated fuse and fuse failure indication.	2910157	IOA REL 120V DI/1.0A/EX
	Relay module for VIP I/O marshalling base elements. For the electrically isolated coupling of 230 V AC field devices to digital inputs. Integrated fuse and fuse failure indication.	2910423	IOA REL 230V DI/1.0A/EX
	Cable monitoring module for VIP I/O marshalling base elements. Enables line fault monitoring when using standard switching contacts in safety applications. Both wire breaks and short circuits can be detected.	1048209	IOA LM-DI/R/RUSIO/EX
	Digital-to-analog converter for VIP I/O marshalling base elements. For connection of four digital inputs and conversion to a single analog 4...20 mA signal. Saves three I/O channels.	1145061	IOA DAC-4DI/AI/EX
	Ex i isolation switch amplifier for connection to Ex i NAMUR sensors and to Schneider Electric Foxboro I/A series FBM 247 UIO, and for VIP I/O marshalling base elements. SIL 2 / SC 3	1663315	IOA MCR-EX-NAM-FBM247
	Ex i isolation switch amplifier for connection to Ex i NAMUR sensors and to Schneider Electric Foxboro I/A series FBM 248 UIO, and for VIP I/O marshalling base elements. SIL 2 / SC 3	1663321	IOA MCR-EX-NAM-FBM248
	Ex i isolation switch amplifier for connection to Ex i NAMUR sensors and to Schneider Electric Foxboro I/A series FBM 247/248 UIO, and for VIP I/O marshalling base elements. SIL 2 / SC 3	1085769	IOA MCR-EX-NAM-NAM
	Ex i isolation switch amplifier for connection to Ex i NAMUR sensors and to Schneider Electric Tricon CX Safety UIO, and for VIP I/O marshalling base elements. SIL 2 / SC 3	1085768	IOA MCR-EX-NAM-TRI
	Ex i isolation switch amplifier for connection to Ex i NAMUR sensors and to Schneider Electric Tricon CX Safety UIO, and for VIP I/O marshalling base elements. SIL 3 / SC 3	1085767	IOA MCR-EX-NAM-TRI-FS
	Ex i isolation switch amplifier for connection to Ex i NAMUR sensors and to Honeywell PKS C300 UIO-2, and for VIP I/O marshalling base elements. SIL 2 / SC 3	1085770	IOA MCR-EX-NAM-C300
	Ex i isolation switch amplifier for connection to Ex i NAMUR sensors and to Honeywell RUSIO Safety UIO, and for VIP I/O marshalling base elements. SIL 2 / SC 3	1085772	IOA MCR-EX-NAM-RUSIO

# Product overview – VIP I/O marshalling for universal I/O systems

1

2

3



I/O signal marshalling

## Digital OUT

Solenoid drivers are used to transmit control signals to solenoid valves located in the intrinsic safety area. Relay modules for digital output signals switch loads up to 3 A and 230 V into the field. The IOAs are available with SIL and optionally with Ex i approval.



## Digital OUT



	Description	Item no.	Type
	Relay module for VIP I/O marshalling base elements. For switching 24 V DC loads up to max. 3 A. Integrated fuse and fuse failure indication. N/O contact or N/C contact can be used.	2910153	IOA REL 24V DO/BFI/3.0A/EX
	Relay module for VIP I/O marshalling base elements. For switching 120 V AC loads up to max. 3 A. Integrated fuse and fuse failure indication. N/O contact or N/C contact can be used.	2910154	IOA REL 120V DO/BFI/3.0A/EX
	Relay module for VIP I/O marshalling base elements. For switching 230 V AC loads up to max. 3 A. Integrated fuse and fuse failure indication. N/O contact can be used.	2910421	IOA REL 230V DO/BFI/NO/3.0A/EX
	Relay module for VIP I/O marshalling base elements. For switching 230 V AC loads up to max. 3 A. Integrated fuse and fuse failure indication. N/C contact can be used.	2910422	IOA REL 230V DO/BFI/NC/3.0A/EX
	Plug-in SIL coupling relay as an input/output accessory for VIP base module, SIL 3 high- and low-demand applications, safe-state-off, couples digital output signals to the periphery, one enabling current path, one confirmation current path, test pulse filter	2702971	IOA-PSR-PS22-1NO-1NC-24DC
	Plug-in SIL coupling relay as an input/output accessory for VIP base module, SIL 3 low-demand, safe-state-on, couples digital output signals to the periphery, active error feedback, one confirmation current path test pulse filter, load monitoring	1103578	IOA PSR-PC51-1NO-24DC
	Ex i solenoid driver for VIP I/O marshalling base elements: for controlling Ex i solenoid valves in potentially explosive areas, logic input, no-load voltage 15.95 V, current limitation at 50 mA, line fault transparency, up to SIL 3 in accordance with IEC 61508	1095564	IOA MCR-EX-SD-16-50
	Ex i solenoid driver for VIP I/O marshalling base elements: for controlling Ex i solenoid valves in potentially explosive areas, logic input, no-load voltage 19.95 V, current limitation at 25 mA, line fault transparency, up to SIL 3 in accordance with IEC 61508	1095563	IOA MCR-EX-SD-20-25
	Ex i solenoid driver for VIP I/O marshalling base elements: for controlling Ex i solenoid valves in potentially explosive areas, logic input, no-load voltage 20.85 V, current limitation at 48 mA, line fault transparency, up to SIL 3 in accordance with IEC 61508	1291156	IOA MCR-EX-SD-21-48
	Ex i solenoid driver for VIP I/O marshalling base elements: for controlling Ex i solenoid valves in potentially explosive areas, logic input, no-load voltage 22.3 V, current limitation at 38 mA, line fault transparency, up to SIL 3 in accordance with IEC 61508	1085763	IOA MCR-EX-SD-23-38

# Product overview – VIP I/O marshalling for universal I/O systems

## Temperature

Monitoring temperatures in process technology plants is a fundamental requirement. Resistance thermometers and thermocouples are often used for this purpose. IOAs are used as temperature measuring transducers, optionally with SIL and Ex i approval, for the accurate and error-free transmission of measuring signals.



Temperature			
	Description	Item no.	Type
	Ex i temperature measuring transducer for VIP I/O marshalling base elements: Converts signals from resistance thermometers installed in Ex areas and transmits a 0/4 mA ... 20 mA signal to a load (active or passive) in the safe area. Freely configurable.	1085764	IOA MCR-EX-RTD-I
	Ex i temperature measuring transducer for VIP I/O marshalling base elements: Converts signals from thermocouples installed in Ex areas and transmits a 0/4 mA ... 20 mA signal to a load (active or passive) in the safe area. Freely configurable.	1085766	IOA MCR-EX-TC-I
	Ex i temperature measuring transducer for VIP I/O marshalling base elements: Converts signals from temperature sensors installed in the Ex area and transmits a 0/4 mA ... 20 mA signal to a load (active or passive) in the safe area. Freely configurable.	1085760	IOA MCR-EX-T-I
	Temperature measuring transducer for VIP I/O marshalling base elements: Converts signals from resistance thermometers and transmits a 0/4 mA ... 20 mA signal to a load (active or passive). Freely configurable.	1007728	IOA MCR-RTD-I
	Temperature measuring transducer for VIP I/O marshalling base elements: Converts signals from thermocouples and mV sources and transmits a 0/4 mA .... 20 mA signal to a load (active or passive). Freely configurable.	1007722	IOA MCR-TC-I
	Temperature measuring transducer for VIP I/O marshalling base elements: Converts signals from temperature sensors and transmits a 0/4 mA ... 20 mA signal to a load (active or passive). Freely configurable.	1176866	IOA MCR-T-I

# Product overview – VIP I/O marshalling for universal I/O systems

1

2

3



I/O signal marshalling

## Passive modules

The passive function blocks perform a variety of basic functions, such as protecting signal and supply paths, limiting current and voltage to the field, and unfiltered signal forwarding.



### Passive

	Description	Item no.	Type
	Feed-through terminal block for VIP I/O marshalling base elements for conveying field signals to or from the I/O system.	2906598	IOA FEED-THRU/EX
	Fuse module for VIP I/O marshalling base elements with replaceable 0.25 A fuse in the field device supply path. Integrated test points and a disconnect knife allow uninterrupted signal measurement.	1188706	IOA PR-DAI/DAO/F/DS/0.25A/EX
	Fuse module for VIP I/O marshalling base elements with replaceable 2 A fuse in the field device supply path. Integrated test points and a disconnect knife allow uninterrupted signal measurement.	1048208	IOA PR-DAI/DAO/F/DS/2A/EX
	Fuse module for VIP I/O marshalling base elements with replaceable 0.5 A fuses in the field device supply path and in the signal path. Integrated test points and a disconnect knife allow uninterrupted signal measurement.	2906599	IOA AI/AO/BFI/DS/0.5A/EX
	Fuse module for VIP I/O marshalling base elements with replaceable 1 A fuses in the field device supply path and in the signal path. Integrated test points and a disconnect knife allow uninterrupted signal measurement.	2906600	IOA DI/DO/BFI/DS/1.0A/EX

# Process displays and field devices

3

The Field Analog process displays enable you to monitor and locally display analog and temperature signals, and to control them via digital and analog inputs and outputs. The loop-powered temperature measuring transducers acquire and convert the signals from resistance thermometers, thermocouples, resistance-type sensors, and voltage sensors directly in the field and convert them into standard and HART® signal.



## Field Analog field devices

- Loop-powered temperature measuring transducers
- Loop-powered head-mounted temperature measuring transducers

## Resistor network for proximity switches

- Resistance networks with different resistance values, parallel and in series



## Field Analog process displays

- Multifunctional process displays
- Output-loop-powered process displays
- 7-segment LED displays



## HART® communication

- For online configuration and diagnostics for HART®-compatible field devices
- Continuous documentation of process variables and states via PC or management system

## Process displays

The Field Analog series process displays enable you to monitor and display analog and temperature signals, and to control them via digital and analog inputs and outputs, even in the Ex area. The products are available for control-panel mounting or for decentral installation directly in the field. Benefit from easy configuration, good readability, and international approvals.



### Your advantages

- ✓ Easy configuration via front keypad or with FDT/DTM software
- ✓ Everything at a glance: values, bar graphs, and measuring point designations, plus color change in the event of an error
- ✓ Easy installation: standardized housing dimensions and plug-in connection terminal blocks
- ✓ Digital transfer and display of process data with HART®-compatible display versions
- ✓ International approvals and versions with ATEX/IECEX, CSA, and FM approval

## Your advantages in detail



### Multifunctional process displays

Our multifunctional process displays acquire current, voltage, RTD, TC, and resistance-type sensor signals via the universal input. Current process values are easy to read on the five-digit backlit displays. The bar graph also provides you with a quick overview. Alarm states can be identified easily from a distance because the display changes to red.



### Output-loop-powered process displays

The output loop-powered process displays display your 4 mA ... 20 mA and HART® signals. Up to four alternating measured values from a sensor are mapped via HART®. Benefit from the low voltage drop of less than one volt (<1.9 V HART®) when used in Ex applications, where only a limited voltage is usually available.



### 7-segment LED displays

The compact process displays offer you cost-efficient monitoring of standardized current and voltage signals as well as frequency and pulse signals. In addition, the setpoint adjuster for standard signals helps you to easily integrate standardized signals or a freely programmable, time-controlled signal sequence of 0 ... 12 V or 0 ... 24 mA into your process.

1

2

3

Process displays and field devices

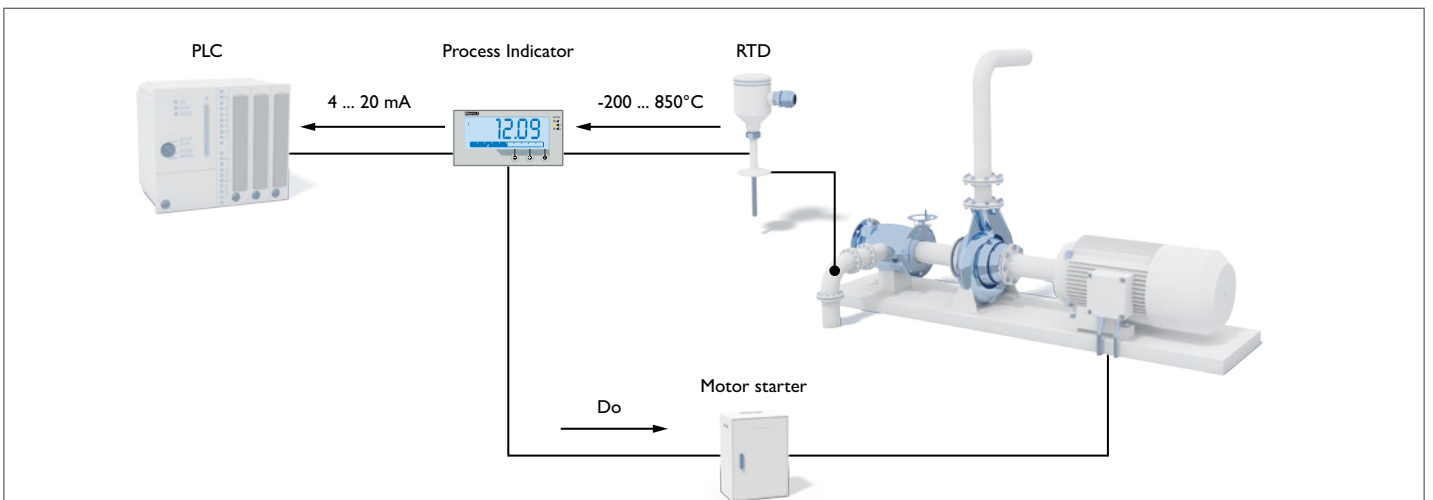

### Recording limit values with multifunctional Field Analog process displays









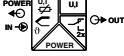
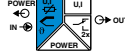

The multifunctional FA MCR(-EX)-D-TUI-UI-2REL-UP process displays are particularly suitable as limit switches for monitoring limit values. The products continuously record your process values and switch the relay outputs as soon as a value exceeds or drops below the set limit value.

#### Example of pumped-medium temperature monitoring

In pump applications, it is useful to monitor the liquid being pumped. This helps in preventing drive overloads. If the solidifying point of the pumped medium is above the ambient temperature, the medium temperature monitoring system stops the pump from starting up until the

viscosity of the medium allows operation. In this process, the temperature signals are continuously monitored for upper and lower limit violations and controlled by the process display.

# Product overview – Field Analog process displays

Multifunctional process displays		
		
<b>Product type</b>	Digital display	
		
<b>Description</b>	Multifunctional process display in the control panel component housing, wide-range supply	Multifunctional Ex i process display in the control panel component housing, wide-range supply
		
<b>Approvals</b>	DNV  	DNV     
<b>Ex installation</b>		Ga; Da
<b>Usable input source</b>	RTD: Pt, Ni, Cu sensors / 2-, 3-, 4-conductor / TC: J, K, T, N, B, S, R, U, L, C, D	
<b>Input signal</b>	0 mA ... 20 mA +10% / 4 mA ... 20 mA +10% / 0 V ... 10 V / 2 V ... 10 V / 0 V ... 5 V / 0 V ... 1 V / 1 V ... 5 V / -1 V ... 1 V / -10 V ... 10 V / -30 V ... 30 V / -100 mV ... 100 mV / Resistance thermometers: -200°C ... +1100°C (range depending on sensor type, adjustable) / Thermocouples: -200°C ... +2495°C (range depending on sensor type, adjustable)	
<b>Output signal</b>	0 mA ... 20 mA / 4 mA ... 20 mA / 0 V ... 10 V / 2 V ... 10 V / 0 V ... 5 V / 1 V ... 5 V	
<b>Switching output</b>	Relay output (2 changeover contacts) / transistor output, active (open collector output)	
<b>Display</b>	Number of digits displayed: 5 / 7-segment LC display, with backlight, dot matrix for text/bar graph	
<b>Supply voltage</b>	24 V AC/DC ... 230 V AC/DC	
<b>Ambient temperature range</b>	-20°C ... +60°C	
<b>Fault signaling: LED</b>	No	
<b>Configuration</b>	Keyboard / software	
<b>Mounting type</b>	DIN rail mounting / front panel installation	
<b>Width</b>	96 mm	
<b>Delivery state</b>	Standard configuration	
<b>Type</b>	FA MCR-D-TUI-UI-2REL-UP	FA MCR-EX-D-TUI-UI-2REL-UP
<b>Connection method</b>	Push-in connection	
<b>Item no.</b>	2907064	2907216

 The module can be snapped onto the DIN rail bus connector for 24 V voltage bridging

 Wide range input for worldwide supply networks













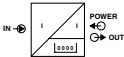
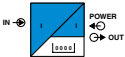



# Product overview – Field Analog process displays



1

2

3

Process displays and field devices

Output-loop powered process displays		
		
<b>Product type</b>	Digital display	
		
<b>Description</b>	Output loop-powered process display in a control panel housing, HART-compatible	Output loop-powered Ex i process display in a control panel housing, HART-compatible
		
<b>Approvals</b>	DNV  ENEC  	DNV    ENEC   Ex    
<b>Ex installation / Ex i switching circuit</b>		Gb; Div. 1 / Gb; Div. 1
<b>Input signal</b>	4 mA ... 20 mA / up to 4x HART process variables	
<b>Output signal</b>	4 mA ... 20 mA / up to 4x HART process variables	
<b>Display</b>	Number of digits displayed: 5 / 7-segment LC display, with backlight, dot matrix for text/bar graph	
<b>Supply voltage</b>	Loop-powered, no external supply necessary	
<b>Ambient temperature range</b>	-40°C ... +60°C	
<b>Fault signaling: LED</b>	No	
<b>Configuration</b>	Keyboard / software	
<b>Mounting type</b>	Front panel installation	
<b>Width</b>	96 mm	
<b>Delivery state</b>	Standard configuration	
<b>Type</b>	FA MCR-DS-I-I-OLP	FA MCR-EX-DS-I-I-OLP
<b>Connection method</b>	Push-in connection	
<b>Item no.</b>	2908781	2908800

LED displays			
	Description	Item no.	Type
	MCR digital display, for measuring and displaying standard signals, 5-digit display	2864011	MCR-SL-D-U-I
	Digital setpoint adjuster with manual and automatic ramp for defining current and voltage signals, 4-digit display	2710314	MCR-SL-D-SPA-UI
	MCR digital display, for measuring and displaying frequencies, pulses, and times, 6-digit display	2864024	MCR-SL-D-FIT

# Loop-powered temperature measuring transducers

Our loop-powered Field Analog temperature measuring transducers acquire and convert signals from temperature sensors such as resistance thermometers, thermocouples, and resistance and voltage sensors into a standard signal directly in the field. Via HART® communication, you can transfer process data digitally and configure the transmitter remotely. The products are available for the DIN rail or as head-mounted measuring transducers.

**Push-in Technology**   
Designed by Phoenix Contact



## Your advantages

- ✔ Record temperatures directly in the field without a separate power supply with loop-powered supply from the measuring circuit
- ✔ Equipped with integrated HART® communication, which enables process data to be transferred and displayed digitally, and also parameterized remotely
- ✔ Suitable for global use due to international approvals
- ✔ Also for intrinsically safe circuits in the Ex area: versions with ATEX/IECEX, CSA, and FM approval

## Your advantages in detail



### Supply from the measuring circuit

All Field Analog temperature measuring transducers are 2-wire transmitters. You do not need a separate power supply, as the products are supplied with power directly via the 4 mA ... 20 mA measuring line. This reduces wiring effort.



### Convenient configuration and monitoring

Conveniently configure the temperature measuring transducers and head-mounted transmitters of the Field Analog product family via HART® communication. In addition, you have the option of receiving extended process data and extensive diagnostic functions from the device via HART®.

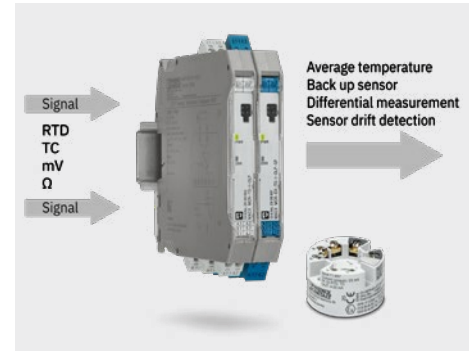

### Dual sensor input

Depending on the device type, some field analog temperature transmitters have a dual sensor input. This allows mathematical functions to be mapped, such as a difference measurement. It is also possible to monitor a process with two different temperature sensors and to switch over from a defined temperature range.





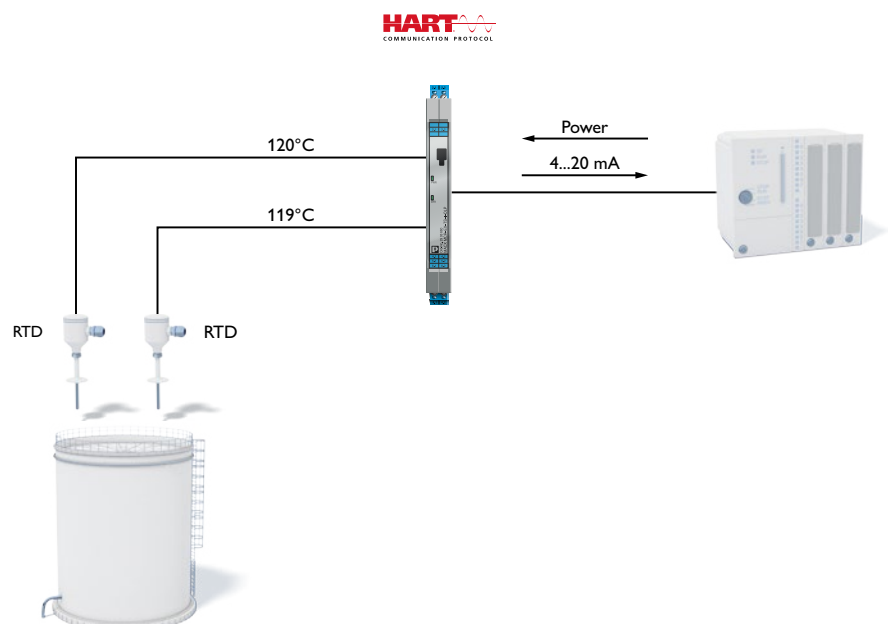

## Easy detection of temperature deviations

With the FA MCR(-EX)-HT-TS-I-OLP and MACX MCR(-EX)-TS-I-OLP(-SP) (-C) temperature transmitters, it is easy to detect temperature deviations in a process. To do this, you can use the dual sensor input of the devices and connect two sensors: For example, you can use two 2-conductor PT100 sensors or one 4-conductor PT100 and one TC sensor. Configuring the temperature transmitter for recording the temperature difference is convenient and simple via the fdtContainer and corresponding DTM. If the temperature at the measuring point deviates, a HART® signal is generated which signals the deviation to the controller.

*\* Please note that two temperature transmitters must be used for SIL 3 applications.*

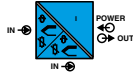

# Product overview – Field Analog field devices

Head-mounted measuring transducers / 2-conductor field devices	
	 
<b>Product type</b>	Temperature measuring transducer
	 
<b>Description</b>	<p>Output loop-powered head-mounted temperature measuring transducer for RTDs, TCs, resistance-type sensors, and voltage sensors, two measuring inputs</p> <p>Output loop-powered Ex i head-mounted temperature measuring transducer for RTDs, TCs, resistance-type sensors, and voltage sensors, two measuring inputs</p>
<b>Approvals</b>	   
<b>Ex installation / Ex i switching circuit</b>	Gc; Div. 2 / -
<b>Functional safety</b>	SIL 2 / SC 3
<b>Usable input source</b>	RTD: Pt, Ni, Cu sensors: 2-, 3-, 4-conductor / TC: A, B, C, D, E, J, K, L, N, R, S, T, U
<b>Input signal</b>	-250°C ... +2500°C (range depending on the sensor type) / linear resistance: 10 Ω ... 2000 Ω (minimum measuring span: 10 Ω) / -20 mV ... 100 mV (minimum measuring span: 5 mV)
<b>Output signal</b>	4 mA ... 20 mA / 20 mA ... 4 mA
<b>Supply voltage</b>	Loop-powered, no external supply necessary
<b>Ambient temperature range</b>	-40°C ... +85°C
<b>Fault signaling: LED</b>	No
<b>Configuration</b>	Software / HART
<b>Mounting type</b>	Installation / DIN rail mounting
<b>Delivery state</b>	Standard configuration
<b>Type</b>	FA MCR-HT-TS-I-OLP
	FA MCR-EX-HT-TS-I-OLP
<b>Connection method</b>	Screw connection
<b>Item no.</b>	1105515
	1105681









# Product overview – Field Analog field devices

1

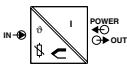







2

3

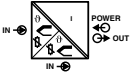
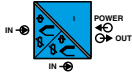
Process displays and field devices

Head-mounted measuring transducers / 2-conductor field devices		
		
<b>Product type</b>	Temperature measuring transducer	
		
<b>Description</b>	Output loop-powered head-mounted temperature measuring transducer for RTDs, TCs, resistance-type sensors, and voltage sensors, one measuring input	Output loop-powered Ex i head-mounted temperature measuring transducer for RTDs, TCs, resistance-type sensors, and voltage sensors, one measuring input
		
<b>Approvals</b>		
<b>Ex installation / Ex i switching circuit</b>	Gc; Div. 2 / -	Gb; Div. 1 / Ga; Div. 1
<b>Usable input source</b>	RTD: Pt, Ni, Cu sensors: 2-, 3-, 4-conductor / TC: A, B, C, D, E, J, K, L, N, R, S, T, U	
<b>Input signal</b>	-250°C ... +2500°C (range depending on the sensor type) / linear resistance: 10 Ω ... 2000 Ω (minimum measuring span: 10 Ω) / -20 mV ... 100 mV (minimum measuring span: 5 mV)	
<b>Output signal</b>	4 mA ... 20 mA / 20 mA ... 4 mA	
<b>Supply voltage</b>	Loop-powered, no external supply necessary	
<b>Ambient temperature range</b>	-40°C ... +85°C	
<b>Fault signaling: LED</b>	No	
<b>Configuration</b>	Software / HART	
<b>Mounting type</b>	Installation / DIN rail mounting	
<b>Delivery state</b>	Standard configuration	
<b>Type</b>	FA MCR-HT-1TS-I-OLP	FA MCR-EX-HT-1TS-I-OLP
<b>Connection method</b>	Screw connection	
<b>Item no.</b>	1145210	1145217

# Product overview – Field Analog field devices

2-conductor field devices					
					
<b>Product type</b>	Temperature measuring transducer				
					
<b>Description</b>	Output loop-powered temperature measuring transducer for RTDs, TCs,, two measuring inputs		Output loop-powered Ex i temperature measuring transducer for RTDs, TCs,, two measuring inputs		
					
<b>Approvals</b>					
<b>Ex installation / Ex i switching circuit</b>	Gc; Div. 2 / -		Gb; Div. 1 / Ga; Div. 1		
<b>Functional safety</b>	SIL 2 / SC 3				
<b>Usable input source</b>	RTD: Pt, Ni, Cu sensors: 2-, 3-, 4-conductor / TC: A, B, C, D, E, J, K, L, N, R, S, T, U				
<b>Input signal</b>	-250°C ... +2500°C (range depending on the sensor type) / linear resistance: 10 Ω ... 2000 Ω (minimum measuring span: 10 Ω) / -20 mV ... 100 mV (minimum measuring span: 5 mV)				
<b>Output signal</b>	4 mA ... 20 mA / 20 mA ... 4 mA				
<b>Supply voltage</b>	Loop-powered, no external supply necessary				
<b>Ambient temperature range</b>	-40°C ... +85°C				
<b>Fault signaling: LED</b>	No				
<b>Configuration</b>	Software / HART				
<b>Mounting type</b>	DIN rail mounting				
<b>Width</b>	12.5 mm				
<b>Delivery state</b>	Standard configuration		Order configuration	Standard configuration	
<b>Type</b>	MACX MCR-TS-I-OLP(-SP)		MACX MCR-TS-I-OLP-C	MACX MCR-EX-TS-I-OLP(-SP)	
<b>Connection method</b>	Push-in connection	Screw connection	Screw connection	Push-in connection	Screw connection
<b>Item no.</b>	2908664	2908662	1012249	2908661	2908660







# Product overview – Field Analog field devices

1

2

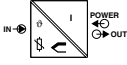
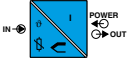
3

Process displays and field devices

2-conductor field devices				
				
<b>Product type</b>	Temperature measuring transducer			
				
<b>Description</b>	Output loop-powered temperature measuring transducer for RTDs, TCs,, one measuring input		Output loop-powered Ex i temperature measuring transducer for RTDs, TCs,, one measuring input	
				
<b>Approvals</b>				
<b>Ex installation / Ex i switching circuit</b>	Gc; Div. 2 / -		Gb; Div. 1 / Ga; Div. 1	
<b>Usable input source</b>	RTD: Pt, Ni, Cu sensors: 2-, 3-, 4-conductor / TC: A, B, C, D, E, J, K, L, N, R, S, T, U			
<b>Input signal</b>	-250°C ... +2500°C (range depending on the sensor type) / linear resistance: 10 Ω ... 2000 Ω (minimum measuring span: 10 Ω) / -20 mV ... 100 mV (minimum measuring span: 5 mV)			
<b>Output signal</b>	4 mA ... 20 mA / 20 mA ... 4 mA			
<b>Supply voltage</b>	Loop-powered, no external supply necessary			
<b>Ambient temperature range</b>	-40°C ... +85°C			
<b>Fault signaling: LED</b>	No			
<b>Configuration</b>	Software / HART			
<b>Mounting type</b>	DIN rail mounting			
<b>Width</b>	12.5 mm			
<b>Delivery state</b>	Standard configuration			
<b>Type</b>	MACX MCR-1TS-I-OLP(-SP)		MACX MCR-EX-1TS-I-OLP(-SP)	
<b>Connection method</b>	Push-in connection	Screw connection	Push-in connection	Screw connection
<b>Item no.</b>	1145196	1145192	1145207	1145365

## HART® communication

The HART® product portfolio provides you with expertise from HART®-transparent interface modules as well as HART®-compatible field devices. A display for control-panel mounting or field installation is available to display the HART® variables. In addition, the HART® multiplexer enables bidirectional communication with up to 32 HART®-compatible field devices. Interconnecting several multiplexer devices enables up to 4,000 channels to be visualized on one PC.

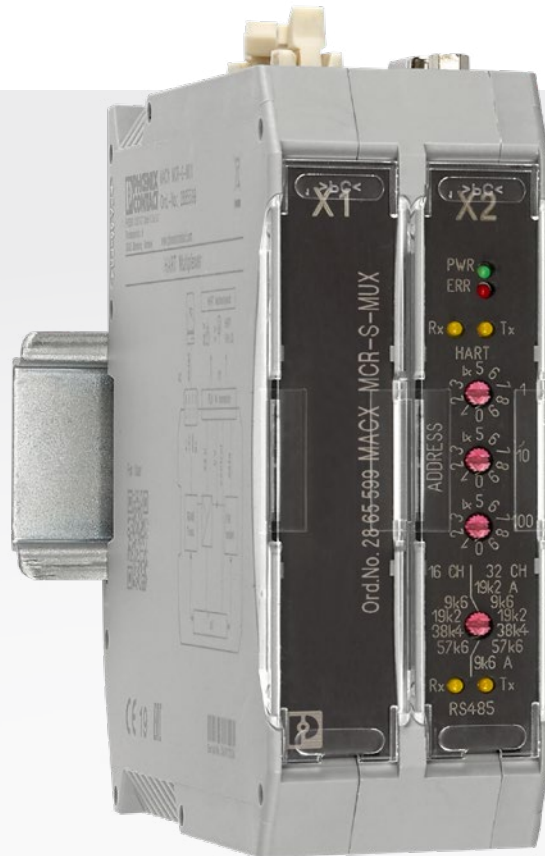

### Your advantages

- ✓ Easy online configuration and diagnostics for HART®-compatible field devices
- ✓ Continuous documentation of process variables and states via PC or management system
- ✓ No influence on measured value processing due to parallel access to the HART® field devices
- ✓ Processing of more than 4,000 channels on one PC, by connecting up to 128 HART® multiplexers with 32 channels each

## Your advantages in detail



### HART® multiplexer communication with field devices

The MACX MCR-S-MUX HART® multiplexer is used for the digital connection of up to 32 HART®-compatible field devices to a PC. The field devices are connected in point-to-point operating mode via the MACX MCR-S-MUX-TB HART® connection board and communicate with the multiplexer via the HART® protocol. The HART® multiplexer communicates with a connected PC via an RS-485 bus.



### HART®-configurable temperature transmitters

Configure the temperature transmitters of the Field Analog product family universally via the HART® signal before installation or during commissioning. At the same time, the transmitters offer you the option of transmitting the measured values and diagnostics data to a connected control system via the HART® protocol for further processing.



### HART®-transparent signal conditioners





The MACX Analog and MINI Analog Pro repeater power supplies/input and output signal conditioners feature HART® transparency. This enables bidirectional communication with the field device via the controller or a HART® handheld device. In addition, the HART® impedance can be increased in low-resistance systems via an additional resistor of the MACX Analog repeater power supply.

1

2

3

Process displays and field devices

HART communication			
	Description	Item no.	Type
	HART multiplexer for the online configuration and diagnostics of HART-compatible field devices as well as the continuous documentation of process variables and states using a PC or management system, for mounting on NS 35/7.5 or NS 32	2865599	MACX MCR-S-MUX
	The HART termination board is used to apply the signals from the HART-compatible signal converters or field devices and transmit them to the MACX MCR-S-MUX HART multiplexer.	2308124	MACX MCR-S-MUX-TB
	The HART termination board is used to apply the signals from the HART-compatible signal converters or field devices and transmit them to the MACX MCR-S-MUX HART multiplexer. The output terminal strip ensures that the analog signals are forwarded.	1292339	MACX MCR-S-MUX-TB-1
	USB HART modem cable for communication between a PC and HART devices, cable length: 1 m.	1003824	GW HART USB MODEM

## Resistor network for proximity switches

The resistor network is used for line fault monitoring of floating contacts and proximity switches via isolation switch amplifiers or digital inputs in accordance with NAMUR IEC/EN 60947-5-6. Benefit from easy handling and the compact design.



### Your advantages

- ✔ Simple way of using floating contacts and proximity sensors to perform line fault monitoring
- ✔ Compatible with isolation switch amplifiers and digital input modules in accordance with NAMUR IEC/EN 60947-5-6
- ✔ Particularly space-saving: can be integrated into transmitter wiring spaces
- ✔ Simple wiring with convenient Push-in Technology

# Your advantages in detail

## Improved safety with line fault monitoring



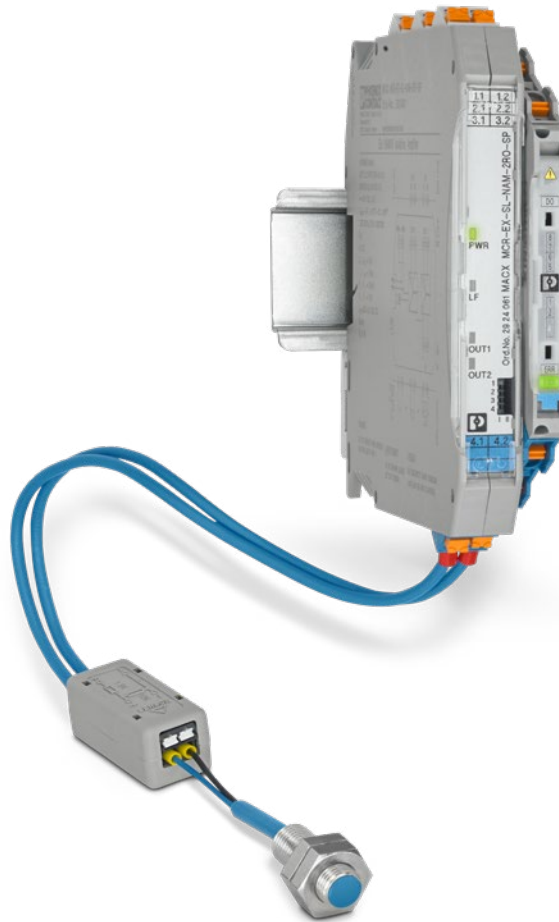

Line fault monitoring is essential in applications with high safety requirements.

The Push-in technology makes it easy for you to integrate the product into existing cabling setups quickly and flexibly. The slim housing enables flexible installation, even in confined areas such as in cable ducts or small transmitter housings.

With the Simple Apparatus explanation for simple equipment that is not a source of ignition, the resistor network is also suitable for use in potentially explosive environments.



## Resistor network for proximity switches

	Description	Item no.	Type
	Resistor network 22 k $\Omega$ parallel, 680 $\Omega$ in series for monitoring floating contacts and proximity switches.	<b>NEW</b> 1642714	FA MCR-FMR-22K-680-IP20-PT
	Resistor network 10 k $\Omega$ parallel, 1 k $\Omega$ in series for monitoring floating contacts and proximity switches.	<b>NEW</b> 1642715	FA MCR-FMR-10K-1K-IP20-PT
	Resistor network 10 k $\Omega$ parallel, 1.5 k $\Omega$ in series for monitoring floating contacts and proximity switches.	<b>NEW</b> 1642716	FA MCR-FMR-10K-1.5K-IP20-PT
	Resistor network 22 k $\Omega$ parallel, 620 $\Omega$ in series for monitoring floating contacts and proximity switches.	<b>NEW</b> 1642820	FA MCR-FMR-22K-620-IP20-PT

## You may also be interested in

### Your individual product with factory calibration certificate

Simply order the suitable product online with the individual configuration for your application. You will then receive modules that are preconfigured to your specifications – even in a minimum quantity of one unit.

Optionally, simply order the appropriate factory calibration certificate for your preconfigured products. The test data is already determined during the production process and supplied directly with the product. This saves you having to deal with an external test laboratory. The certificates are available with or without test data.



### Signal Conditioner App

Configuration, monitoring, identification, all in the palm of your hand: The Signal Conditioner App enables you to identify and configure your products as well as monitor process values more easily than ever before. You also have access to module-specific documents, such as packing slips and data sheets. A DIP switch settings aid is available for products with DIP switches.

Easy connectivity via NFC (MINI Analog Pro), Bluetooth, or QR code. The app is available free of charge for both Android and Apple iOS smartphones.



## clipx ENGINEER software

The configuration software for Phoenix Contact devices includes online monitoring of your current device process values, adjustment of device parameters, and logging of parameter changes. The software is available as a Windows installation version with online update.

### Your advantages

- Smart interfaces to Phoenix Contact applications for control cabinet building and to your CAE programs
- Simplified planning of your projects with the support of intelligent engineering assistants
- Seamless processes from planning to your production through the provision of complete digital data
- Maximum availability for your engineering process with online and offline use



## Services for safety and security in the industry

As a product-independent service provider, we will help you minimize safety and liability risks.

### Process reliability

- Systematic hazard and risk analysis in accordance with DIN EN 61511, including HAZOP study
- Consulting and support for the preparation of SIL assessments in accordance with IEC 61508 and IEC 61511
- Validation of the safety functions and proof test
- Advice on the use of explosion protection components and on operating in explosive atmospheres in accordance with 2014/34/EU and 1999/92/EC

Discover other areas of expertise, such as Industrial Security, CE Marking, and Occupational Safety on our website or in our "Services for safety and security in the industry" brochure.



# COMPLETE line

## The comprehensive solution for the control cabinet

COMPLETE line is a system comprising technologically leading and coordinated hardware and software products, consulting services, and system solutions that help you optimize your processes in control cabinet building. Engineering, purchasing, installation, and operation become significantly easier for you.

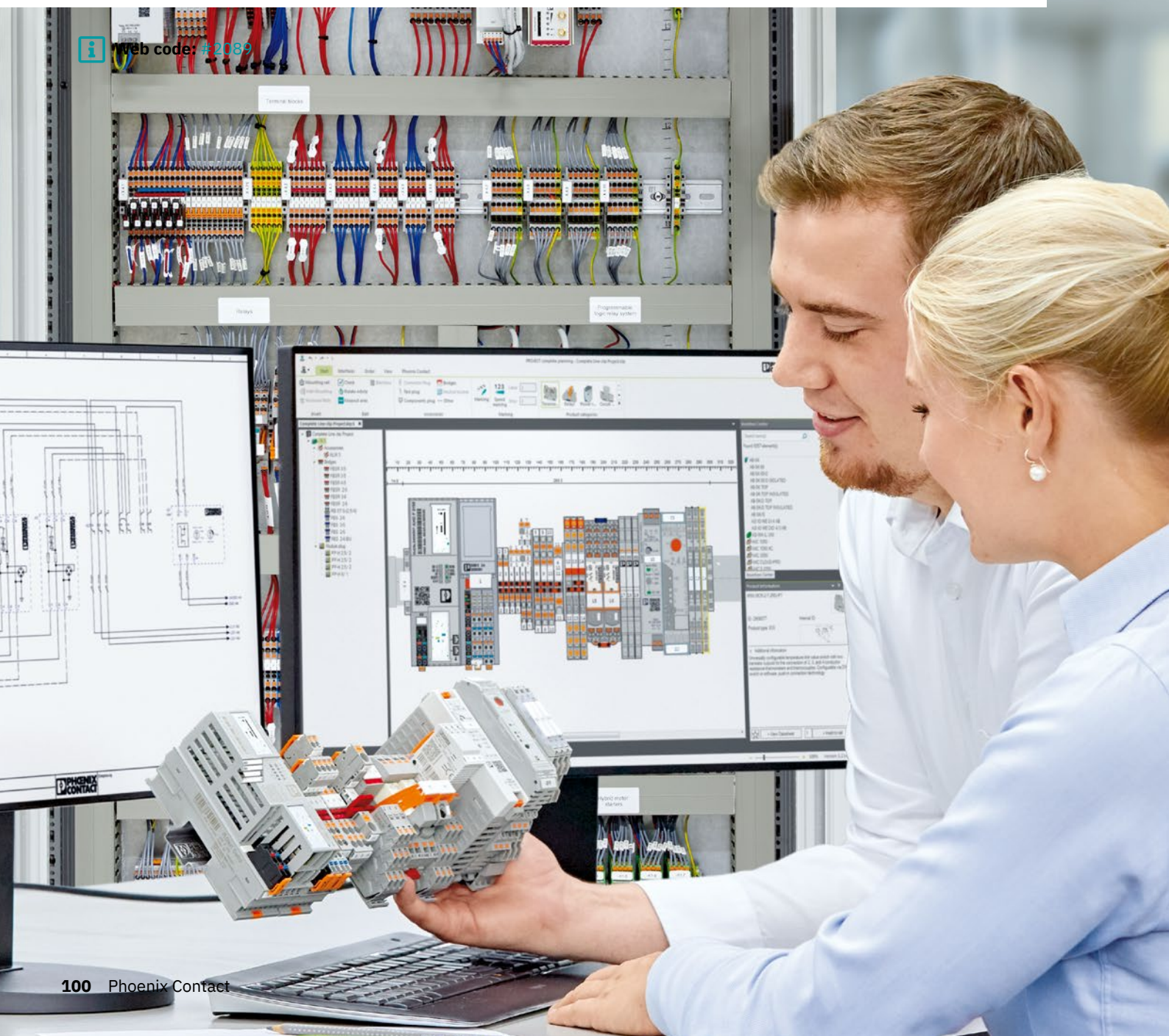

## Your advantages in detail



### Comprehensive product portfolio

With COMPLETE line, we offer a complete product portfolio of technologically leading products. This includes the following:

- Controllers and I/O modules
- Power supplies and device circuit breakers
- Terminal blocks and distribution blocks
- Relay modules and motor starters
- Signal conditioners
- Safety technology
- Surge protection
- Heavy-duty connectors



### Intuitive handling

Thanks to the simple, intuitive handling of the coordinated hardware products you will save time regarding assembly, startup, and maintenance. With Push-in connection technology, you are able to wire applications quickly and without using tools. The broad, technologically leading product portfolio will always provide you with the right product for standard or special applications.



### Save time throughout the entire engineering process

PROJECT complete planning and marking software supports the entire process of control cabinet building. The program features an intuitive user interface that enables the individual planning, automatic checking, and direct ordering of terminal strips.



### Reduced logistics costs

Reduced variety of parts with standardized marking, bridging, and testing accessories. The COMPLETE line system coordinates products, design, and accessories so that you benefit from maximum reusability and thus reduce your logistics costs.



### Optimized processes in control cabinet building

COMPLETE line supports you, from engineering through to manufacturing, in making your control cabinet production as efficient as possible. Thus, your customized concept for optimizing your processes in control cabinet building is created. Our terminal strip production helps you to flexibly manage order peaks or to supply your control cabinet production with fully assembled DIN rails just in time.



### The new standard for the control cabinet

Discover the extensive COMPLETE line product portfolio and find out more about COMPLETE line and the comprehensive solutions for your control cabinet.

Visit our website:

[phoenixcontact.com/completeline](https://www.phoenixcontact.com/completeline)

## Open communication with customers and partners worldwide

Phoenix Contact is a global market leader based in Germany. We are known for producing forward-thinking products and solutions for the comprehensive electrification, networking, and automation of all sectors of the economy and infrastructure. With a global network, we maintain close relationships with our customers, something we believe is essential for our common success.

You can find your local partner at  
[phoenixcontact.com](https://phoenixcontact.com)

